

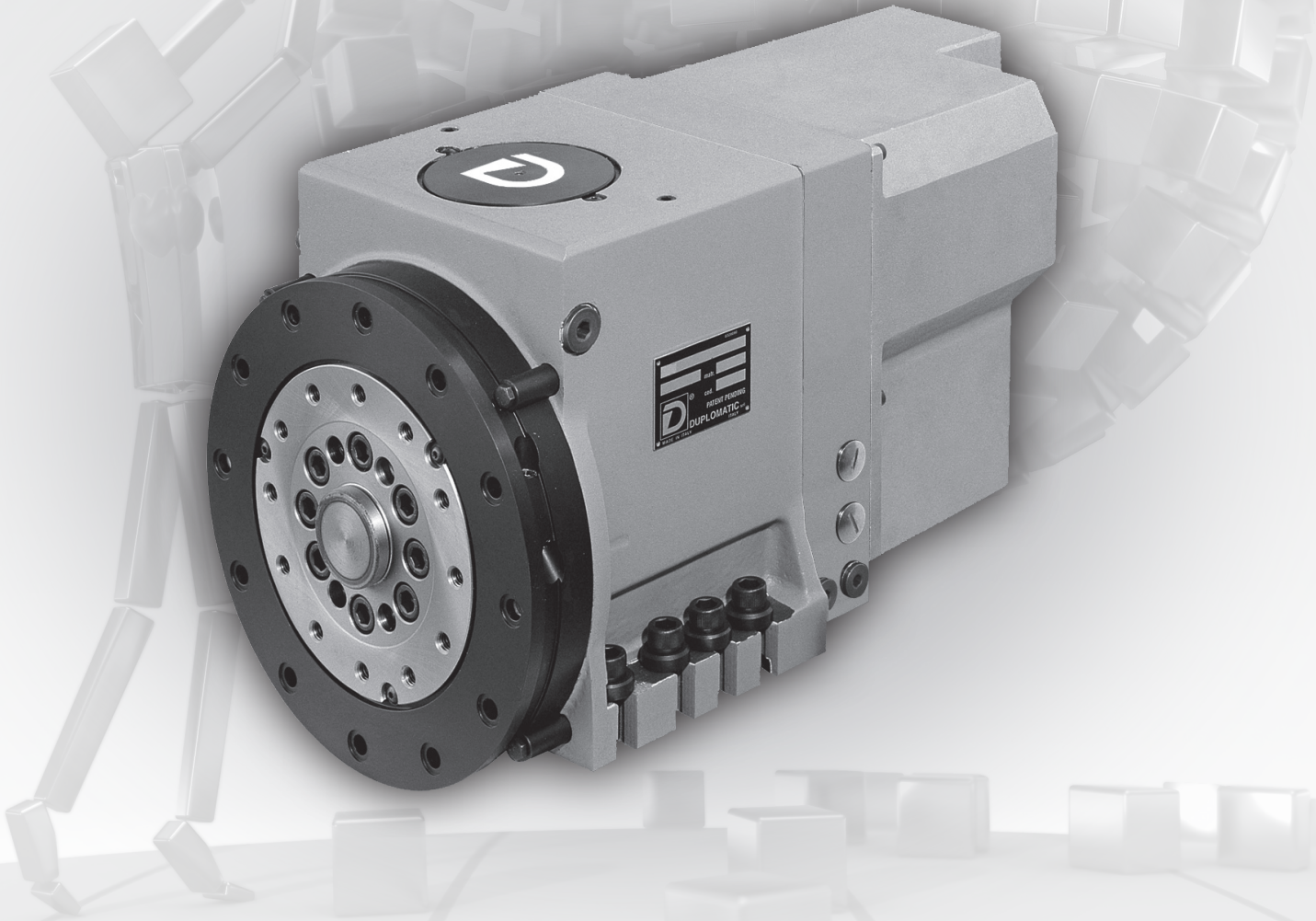

**DIPLOMATIC**  
AUTOMATION



# SM-\* / SMA-\* series 30

## FAST and SUPER FAST SERVOMOTOR TURRETS

(PATENTED)

TECHNICAL INFORMATION



# I.T. 6427

**GB** ISSUED **04-09**

The data given in the I.T. are subject to technical modifications without notice.

The **new 30 SERIES** of the SM(A) servo-turrets is marked by the **DDC4 Control Unit** for the turret indexing cycle control.

This new third generation "smart driver", is the result of a complete re-engineering based on our long lasting experience and using the most advanced technologies (i.e. DSP Digital Control, IPM Intelligent power modules, etc.).

Other main advantages:

- Better design with optimized dimensions and one-only configuration for integrated or remote version.
- Easier electrical connections thanks to the use of common standard connectors.
- Improved diagnostics for a quick and effective trouble-shooting.

### **RESULT: HIGHER PERFORMANCES AND HIGHER RELIABILITY**

The mechanical design is unchanged, perfectly interchangeable with the previous series, allowing the typical performances of the Diplomatic servo-turrets:

#### **Fast indexing**

Drastic reduction of tool-to-tool dead times thanks to the bidirectional stepless movement, driven by a brushless servomotor, as well as the clamping/unclamping without lifting mechanism.

#### **Controlled and smooth indexing**

Controlled accelerations, thanks to the advanced control technology, allow noiseless and shockless positioning, even with high inertia and unbalanced loads.

#### **No lifting clamping mechanism**

The clamping/unclamping mechanism is pneumatically operated and intrinsically safe (patented). An alternative hydraulic version is also available.

#### **High stiffness and accuracy**

Large diameter couplings, strongly clamped, provide high stiffness and high loading capacity. The advanced manufacturing technology of the Hirth-type couplings allow very high accuracy.

The SM\* turret is completely interchangeable with Diplomatic or other brand's electromechanical turrets on the market, as regards foot-print and tool-disc interface and it's pre-arranged to receive the different modular driven tool systems.

The SM\* Turret is supplied equipped with brushless servomotor and relevant electronic control unit:

- it is compatible with every brand of CNC controls
- it doesn't required any CNC expansion
- very simple CNC interfacing and without critical conditions (delays, times to be respected and so on)
- advanced software for easy diagnostic.

SM\* turret is an "**off the shelf**" standard unit, allowing simple and quick installation on the machine and service operations, preset for:

- different frequencies (50/60Hz)
- various load inertia values
- different position numbers (8/12)

As alternative, the control unit can be supplied integrated inside the turret (only on some sized), or for remote installation inside the machine electrical cabinet.

## Indexing times

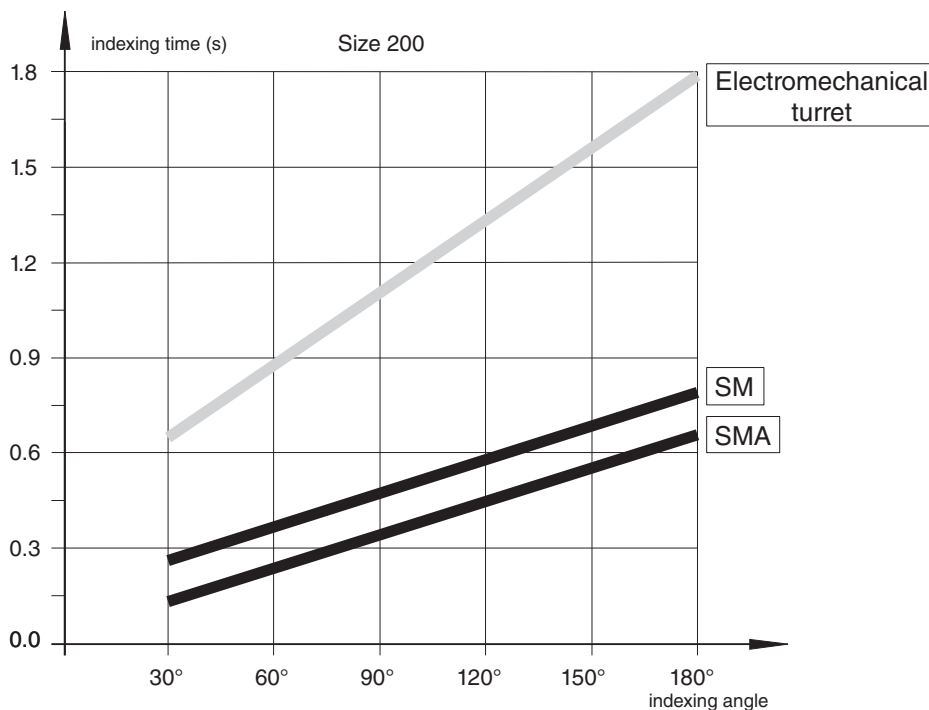

### Quick index:

- 0,14 s/30°** for SM-10
- 0,17 s/30°** for SM-12
- 0,18 s/30°** for SM-16
- 0,24 s/30°** for SM-20
- 0,31 s/30°** for SM-25
- 0,40 s/30°** for SM-32

### Quick index:

- 0,14 s/30°** for SMA-16
- 0,15 s/30°** for SMA-20
- 0,19 s/30°** for SMA-25

## Technical data

Size		SM-10		SM-12		SM-16		SM-20		SM-25		SM-32		
Tool stations	N°	8÷12		8÷12		8÷12		8÷12		8÷12		8÷12		
Inertia of transportable masses (1)	Kgm <sup>2</sup>	0,15	0,30	0,8	1,2	1,2	2,2	3	5	5	9	15	22	
<b>Positioning times:</b> (2)														
one step index time	30°	s	0,14	0,19	0,17	0,21	0,18	0,23	0,24	0,31	0,31	0,40	0,40	0,48
	45°	s	0,18	0,23	0,21	0,25	0,225	0,29	0,30	0,38	0,38	0,48	0,49	0,60
	180°	s	0,54	0,59	0,57	0,61	0,63	0,70	0,74	0,82	0,82	1,15	1,36	1,68
step-less rotation time	30°	s	0,08	0,08	0,08	0,08	0,09	0,09	0,10	0,10	0,10	0,15	0,19	0,24
	45°	s	0,12	0,12	0,12	0,12	0,135	0,135	0,15	0,15	0,15	0,225	0,19	0,36
Tsb Unclamping time or	pneumatic	s	0,10		—		0,10		0,12		0,15		—	
Tb Clamping time (2)	hydraulic	s	0,15		0,14		0,14		0,18		0,22		0,30 / 0,40	
Indexing frequency	$\alpha = 90^\circ$	Cycle/min	18	16	16	14	13	11	12	10	10	8	7	6
Working pressure	pneumatic	bar	5 [ +20% / -10% ]		—		5 [ +20% / -10% ]		5 [ +20% / -10% ]		5 [ +20% / -10% ]		—	
	hydraulic	bar	45 [ ± 10% ]		50 [ + 5% / -20% ]		50 [ + 5% / -20% ]		50 [ + 5% / -20% ]		50 [ + 5% / -20% ]		40 [ ± 15% ]	
Electric supply - Inputs / Outputs		see electric diagram												
Mass (without disc)	Kg	20		40		50		90		115		240		
Ambient temperature range	°C	5 ÷ 40		5 ÷ 40		5 ÷ 40		5 ÷ 40		5 ÷ 40		5 ÷ 40		
Coolant supply:														
Standard:														
• Costant flow (3)	bar	7		7		7		7		7		7		
• Pressure cut-off during turret rotation	bar	14		14		14		14		14		14		
• Option for medium pressure (4)	bar	30		30		30		30		30		30		
Protection degree (DIN 40050)		IP 65		IP 65		IP 65		IP 65		IP 65		IP 65		

(1) Larger inertia values can be applied with increased indexing times

(2) Conditions:

- Pneumatic or hydraulic supply properly sized.
- Without dead-times caused by machine CNC.

(3) Filtering ≤ 150 µm.

(4) Filtering ≤ 50 µm.

**Technical data**

Size			<b>SMA-16</b>		<b>SMA-20</b>		<b>SMA-25</b>	
Tool stations	N°		8÷12		8÷12		8÷12	
Inertia of transportable masses (1)	Kgm <sup>2</sup>		1,2	2,2	2,6	5	5	9
Positioning times: (2)								
one step index time	30°	s	0,14	0,18	0,15	0,19	0,19	0,28
	45°	s	0,19	0,23	0,21	0,25	0,25	0,34
	180°	s	0,59	0,63	0,65	0,69	0,69	0,88
step-less rotation time	30°	s	0,09	0,09	0,10	0,10	0,10	0,12
	45°	s	0,135	0,135	0,15	0,15	0,15	0,18
Tsb Unclamping time or Tb Clamping time (2)	pneumatic	s	0,10		0,12		0,15	
	hydraulic	s	0,14		0,18		0,22	
Indexing frequency	$\alpha = 90^\circ$	Cycle/min	13	11	12	10	10	8
Working pressure	pneumatic	bar $\left[ \begin{smallmatrix} +20\% \\ -10\% \end{smallmatrix} \right]$	5		5		5	
	hydraulic	bar $\left[ \begin{smallmatrix} +5\% \\ -20\% \end{smallmatrix} \right]$	50		50		50	
Electric supply - Inputs / Outputs			see electric diagram					
Mass (without disc)	Kg		50		90		115	
Ambient temperature range	°C		5 ÷ 40		5 ÷ 40		5 ÷ 40	
Coolant supply:								
Standard:								
• Costant flow (3)	bar		7		7		7	
• Pressure cut-off during turret rotation	bar		14		14		14	
• Option for medium pressure (4)	bar		30		30		30	
Protection degree (DIN 40050)			IP 65		IP 65		IP 65	

(1) Larger inertia values can be applied with increased indexing times

(2) Conditions:

- Pneumatic or hydraulic supply properly sized.
- Without dead-times caused by machine CNC.

(3) Filtering  $\leq 150 \mu\text{m}$ .

(4) Filtering  $\leq 50 \mu\text{m}$ .

# SM(A)- \*

## CHARACTERISTICS AND PERFORMANCES

### Accuracy

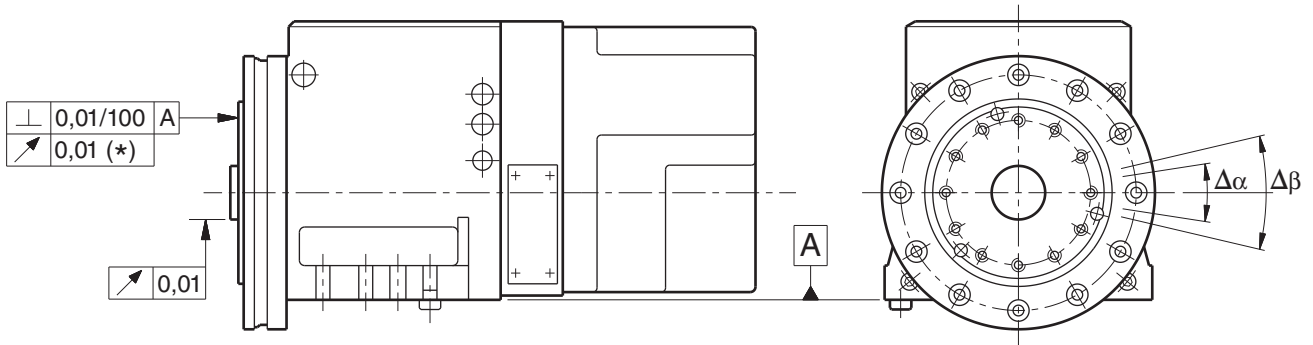

\*) 0,015 for SM-H-32

Repeatability accuracy  $\Delta\alpha = \pm 1,6''$  ( 0,78  $\mu\text{m}/100\text{ mm}$ )

Indexing accuracy  $\Delta\beta = \pm 4''$  ( 1,9  $\mu\text{m}/100\text{ mm}$ )

### Loading capacity

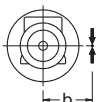
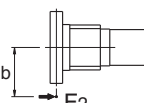
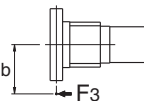
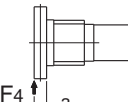
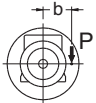
			SM-10	SM-12	SM(A)-16	SM(A)-20	SM(A)-25	SM-32
	Max. tangential torque $F_1 \times b$	Nm	400	750	1.600	3.500	6.000	13.000
	Max. tilting torque to push $F_2 \times b$	Nm	360	900	1.900	5.200	10.000	18.000
	Max. tilting torque to lift $F_3 \times b$	Nm	180	500	1.500	3.000	4.500	8.500
	Max. radial tilting torque $F_4 \times a$	Nm	180	500	1.500	3.000	4.500	8.500
	Unbalancing torque $P \times b$	Nm	10	16	22	40	60	120

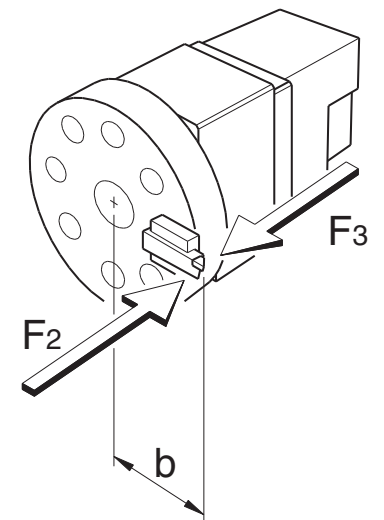
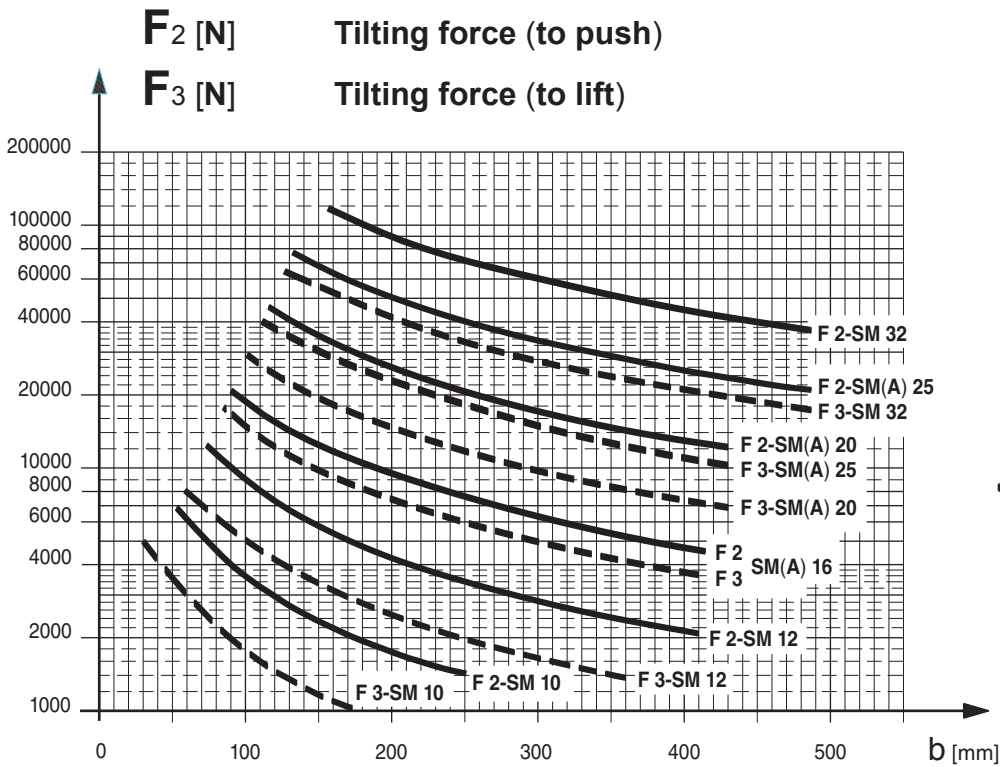
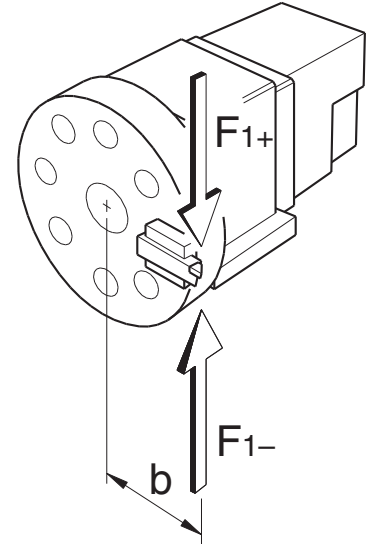
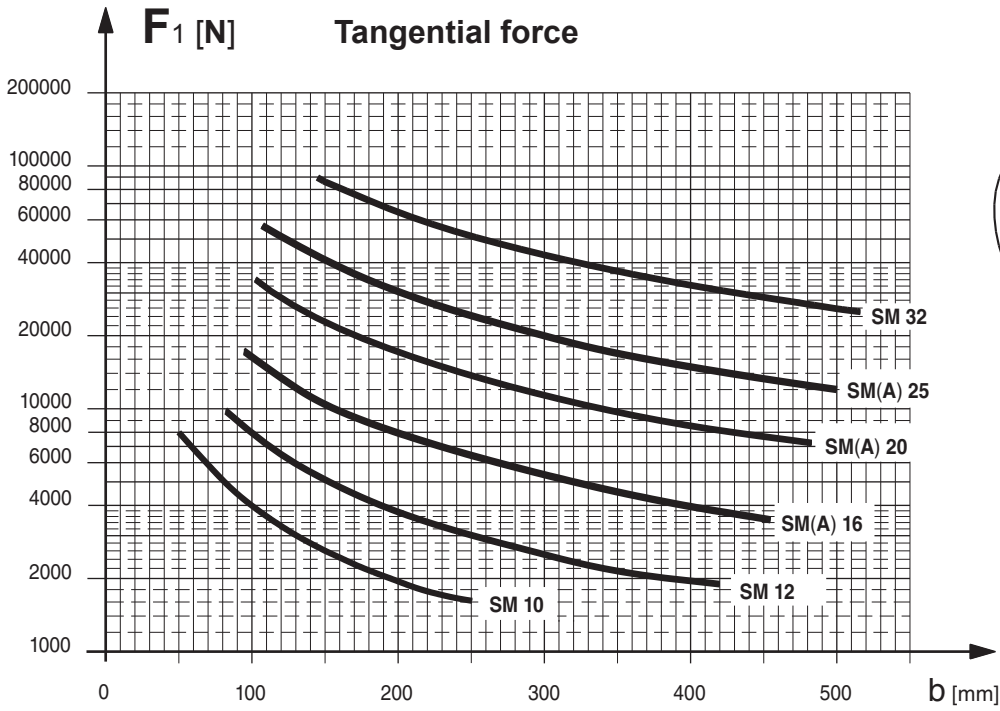

# SM-*\**-10 / series 00

## OVERALL DIMENSIONS

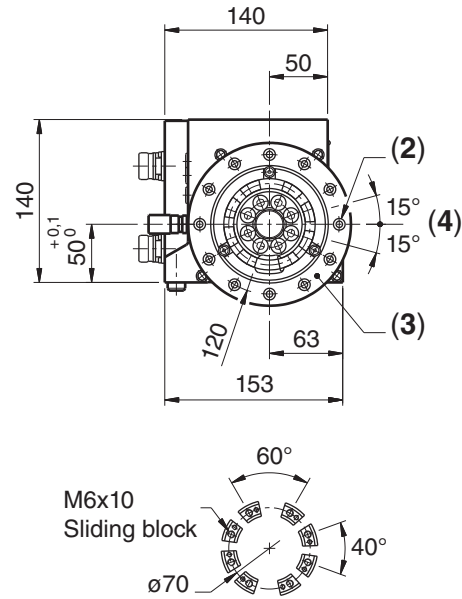
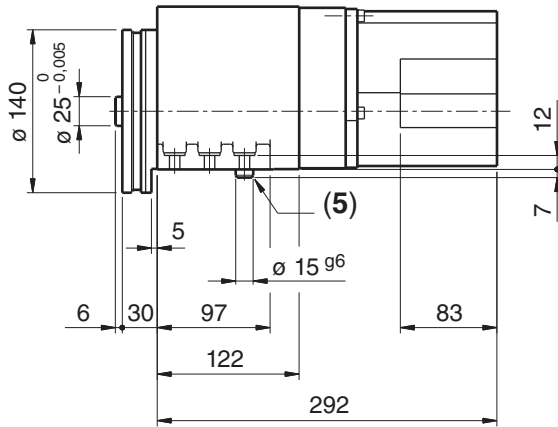

TOOL DISC FIXING SPECS

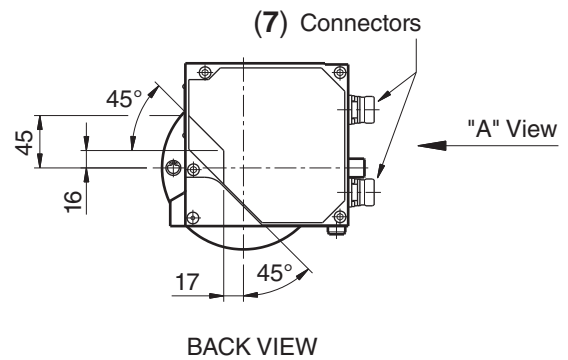
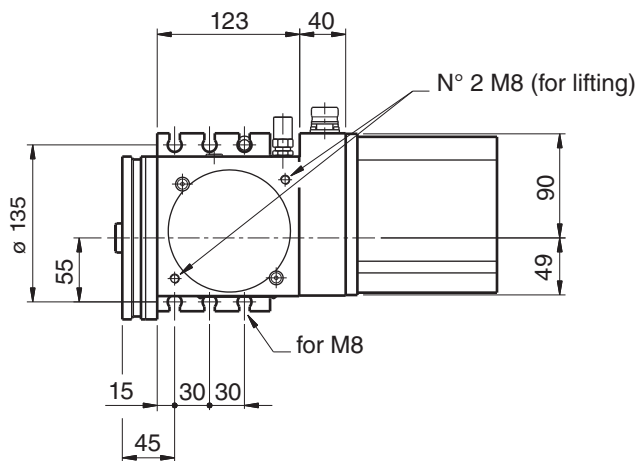

BACK VIEW

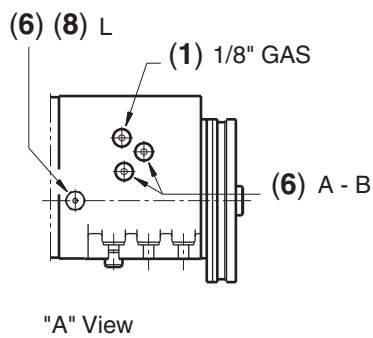

"A" View

TOOL DISC INTERFACE

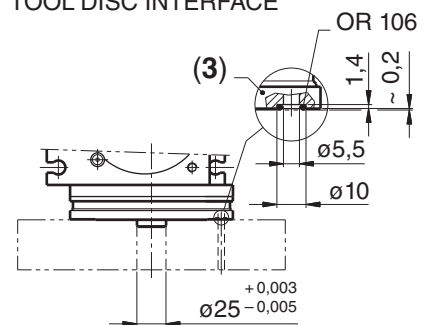

- 1) Inlet coolan position.
- 2) Coolant outlet.
- 3) Adjustable coolant ring.
- 4) Coolant outlet displacement range.
- 5) Reference pin.
- 6) Pneumatic or Hydraulic connections.  
For ports size see sheet 14 and 15.

- 7) Electrical connectors.
- 8) Safety valve (drain) for hydraulic version.

**Note:** Main overall dimensions and fixing are interchangeable with BSV-N100 turrets.  
Drawing shows right turret.  
Left version turret is mirror-image.



## SM-H-12 / series 30

### OVERALL DIMENSIONS

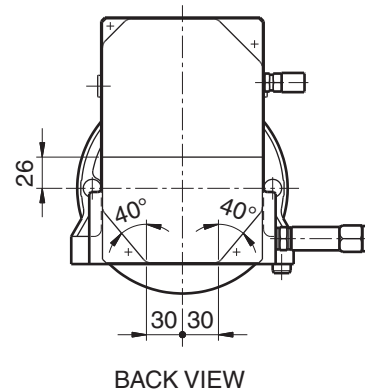
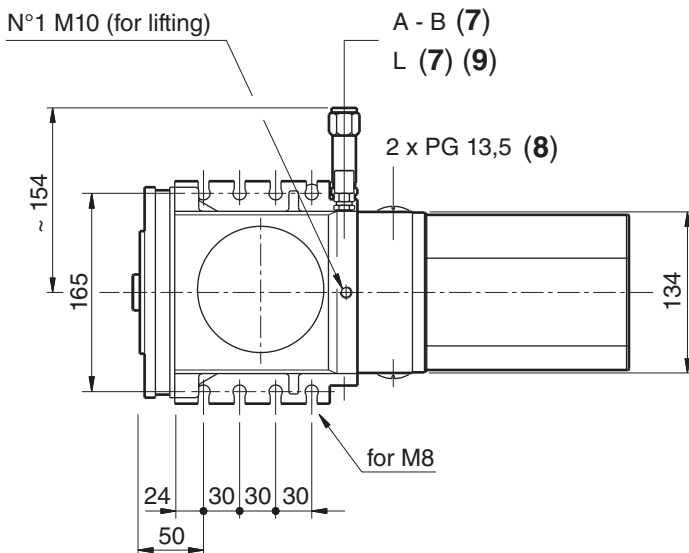
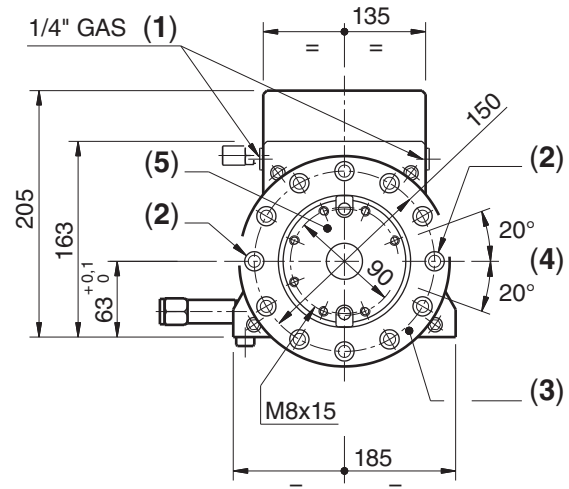
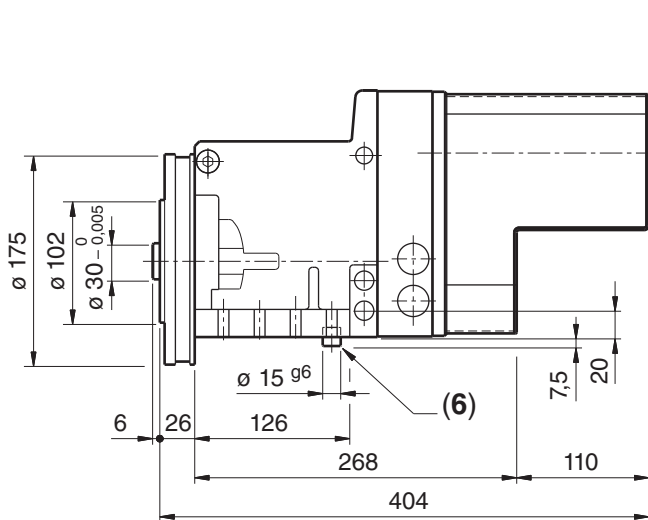

#### TOOL DISC INTERFACE

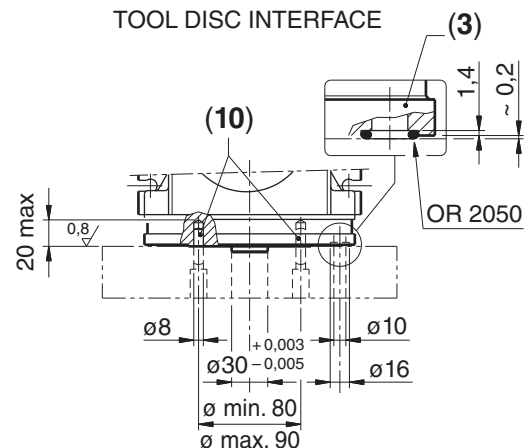

**N.B.:** The SM-12 is available in hydraulic version only, with Control Unit for remote installation. (see sheet 18).

- 1) Inlet coolant positions, at choice.
- 2) Right or left coolant outlet position.
- 3) Adjustable coolant ring.
- 4) Coolant outlet displacement range.
- 5) Soft surface for boring the reference pins.
- 6) Reference pin to be positioned on both sides, at choice.
- 7) Hydraulic connections on both sides, at choice.  
For ports size see sheet 14 and 15.  
(Throttler valve on "B" port; see hydraulic diagram sheet 15).

- 8) Electrical connections.  
**Important:** the connection cables must be provided with fittings and gaskets in order to avoid penetration of water into the turret.
- 9) Safety valve (drain).
- 10) Reference pins between tool disc and turret.

**Note:** Overall dimensions and fixing interchangeable with SM\* turrets of previous series.

# SM(A)-\*-16 / series 30

## OVERALL DIMENSIONS

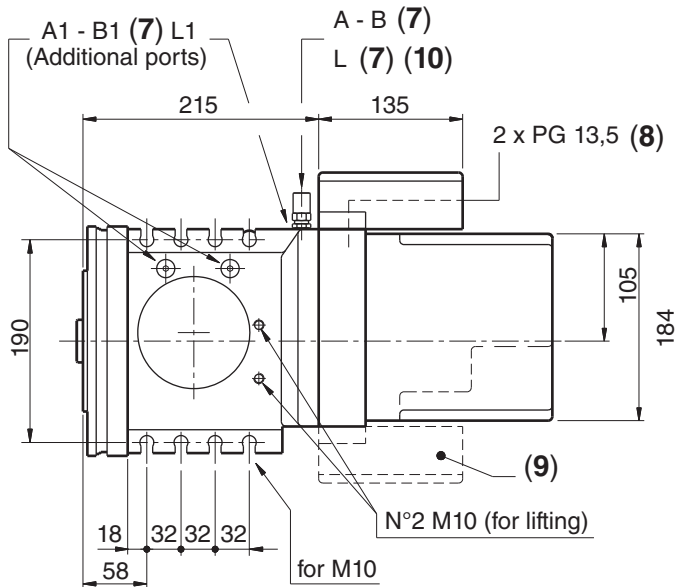
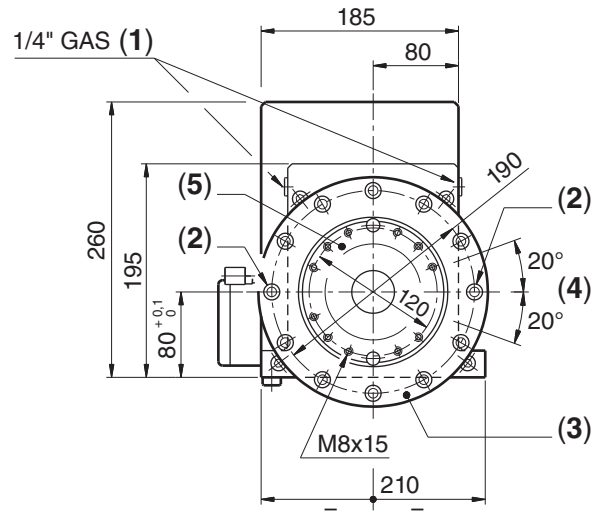
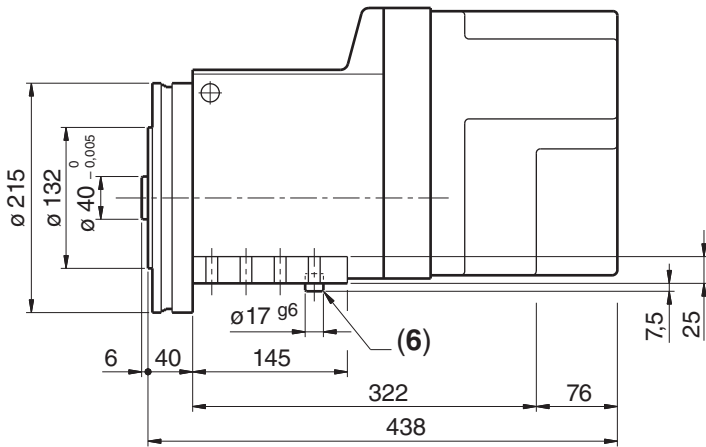

ELECTRICAL CONNECTIONS BOX

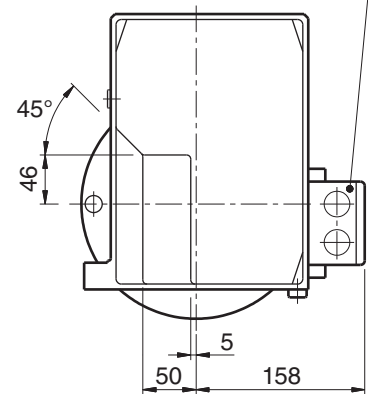

BACK VIEW

TOOL DISC INTERFACE

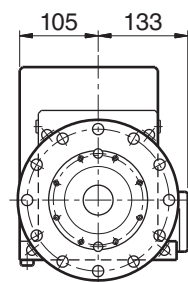
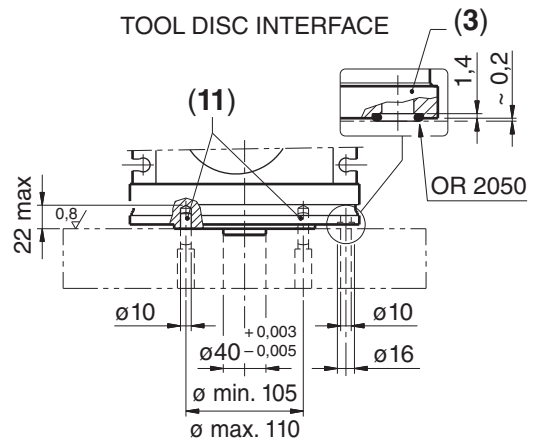

LEFT VERSION

- 1) Inlet coolant positions, at choice.
- 2) Right or left coolant outlet position.
- 3) Adjustable coolant ring.
- 4) Coolant outlet displacement range.
- 5) Soft surface for boring the reference pins.
- 6) Reference pin to be positioned on both sides, at choice.
- 7) Pneumatic or Hydraulic connections.  
For ports size see sheet 14 and 15.
- 8) Electrical connections.
- 9) Electrical box position for left version.
- 10) Safety valve (drain) for hydraulic version.
- 11) Reference pins between tool disc and turret.

**Note:** Overall dimensions and fixing interchangeable with SM\* turrets of previous series.

# SM(A)-\*-20 / series 30

## OVERALL DIMENSIONS

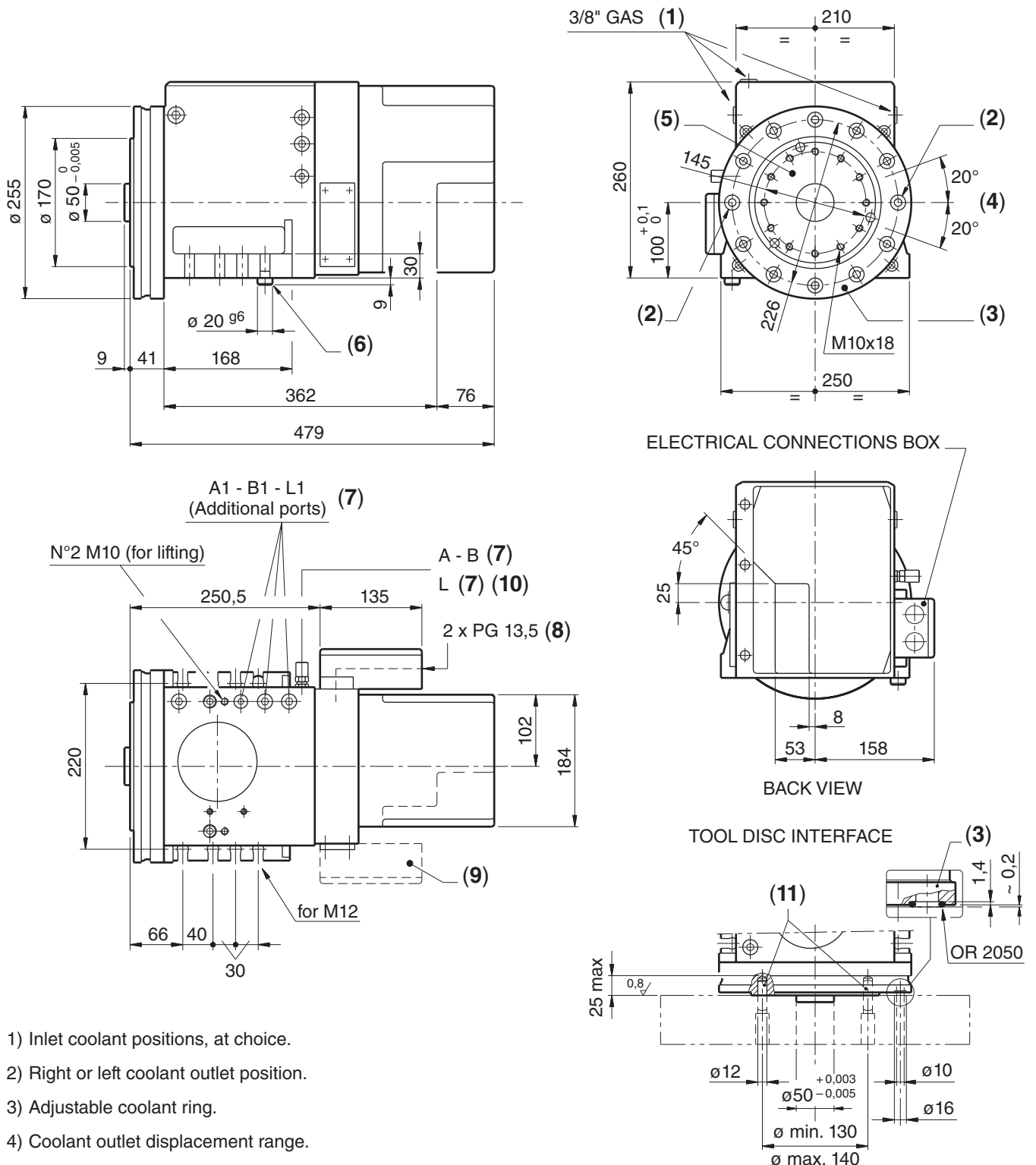

- 1) Inlet coolant positions, at choice.
- 2) Right or left coolant outlet position.
- 3) Adjustable coolant ring.
- 4) Coolant outlet displacement range.
- 5) Soft surface for boring the reference pins.
- 6) Reference pin to be positioned on both sides, at choice.

7) Pneumatic or Hydraulic connections on both sides, at choice.

For ports size see sheet 14 and 15.

8) Electrical connections.

**Important:** the connection cables must be provided with fittings and gaskets in order to avoid penetration of water into the turret.

9) Electrical box position for left version.

10) Safety valve (drain) for hydraulic version.

11) Reference pins between tool disc and turret.

**Note:** Overall dimensions and fixing interchangeable with SM\* turrets of previous series.

# SM(A)-\*-25 / series 30

## OVERALL DIMENSIONS

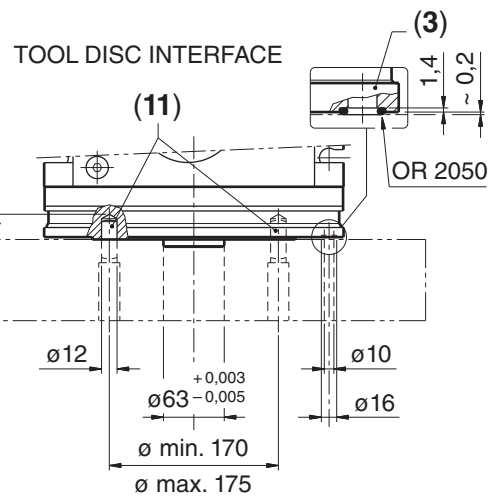
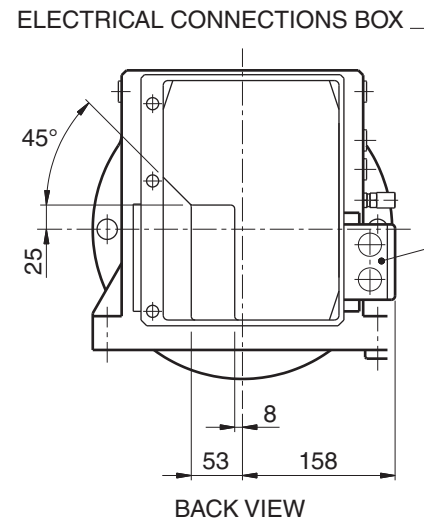
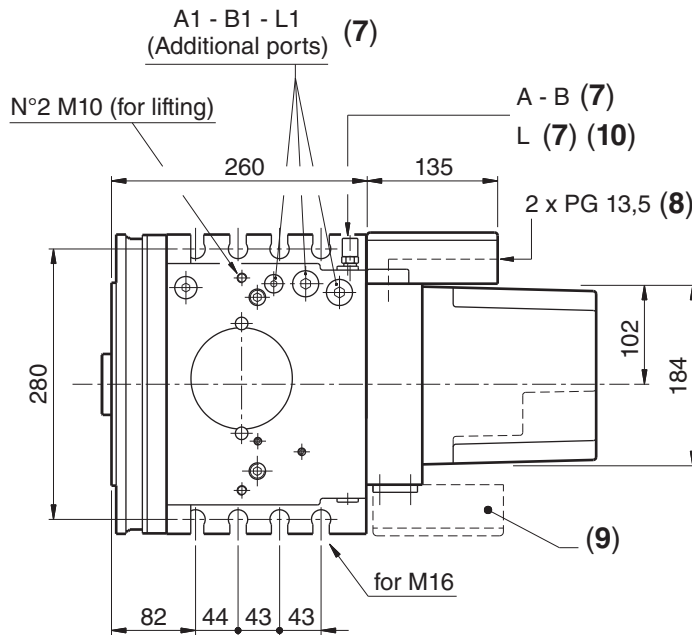
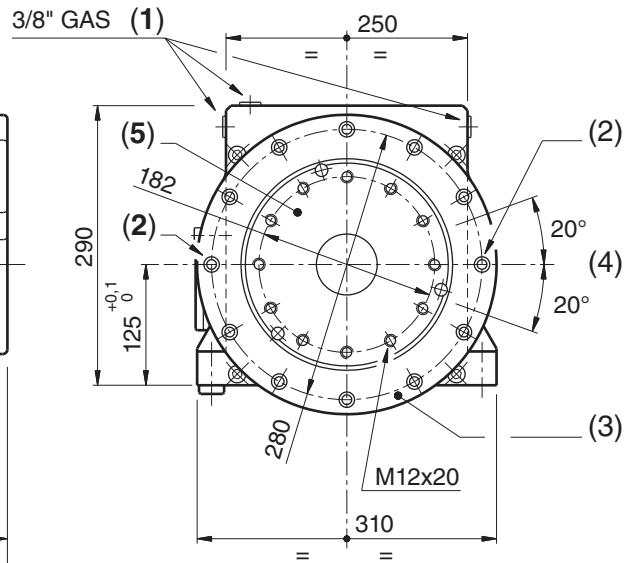
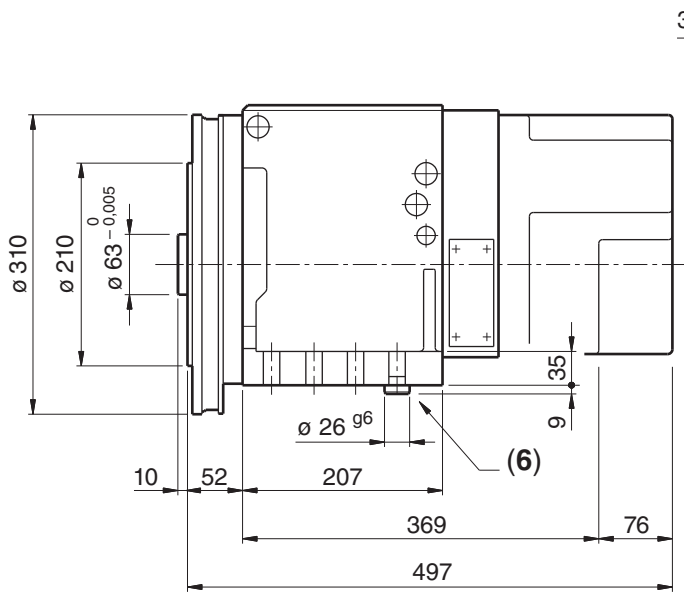

- 1) Inlet coolant positions, at choice.
- 2) Right or left coolant outlet position.
- 3) Adjustable coolant ring.
- 4) Coolant outlet displacement range.
- 5) Soft surface for boring the reference pins.
- 6) Reference pin to be positioned on both sides, at choice.

7) Pneumatic or Hydraulic connections on both sides, at choice.  
For ports size see sheet 14 and 15.

8) Electrical connections.

**Important:** the connection cables must be provided with fittings and gaskets in order to avoid penetration of water into the turret.

- 9) Electrical box position for left version.
- 10) Safety valve (drain) for hydraulic version.
- 11) Reference pins between tool disc and turret.

**Note:** Overall dimensions and fixing interchangeable with SM\* turrets of previous series.

# SM-H-32 / series 00

## OVERALL DIMENSIONS

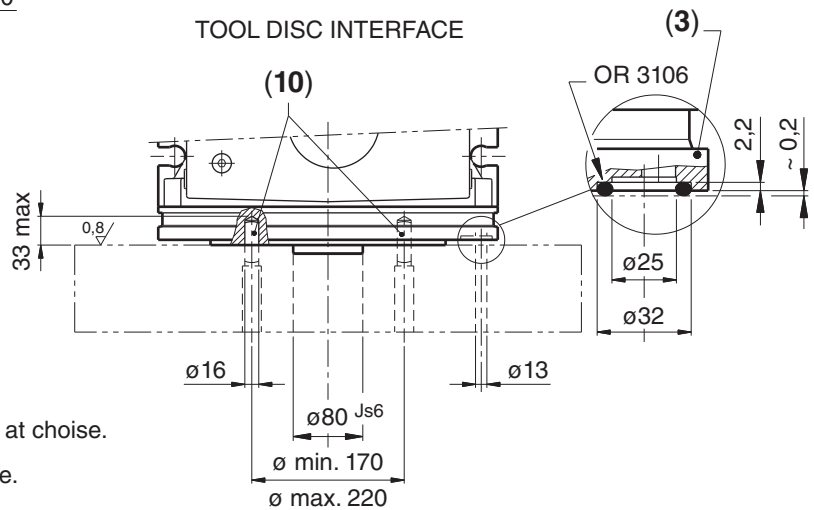
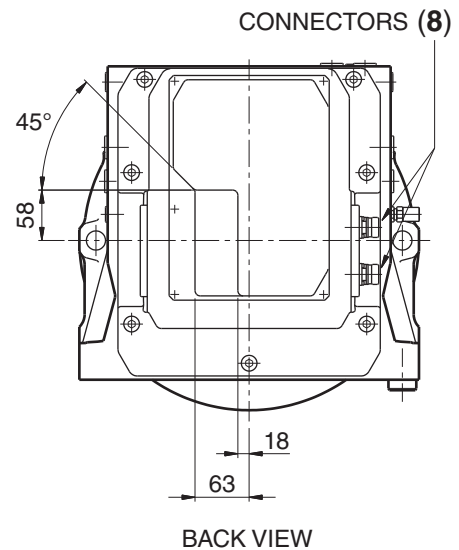
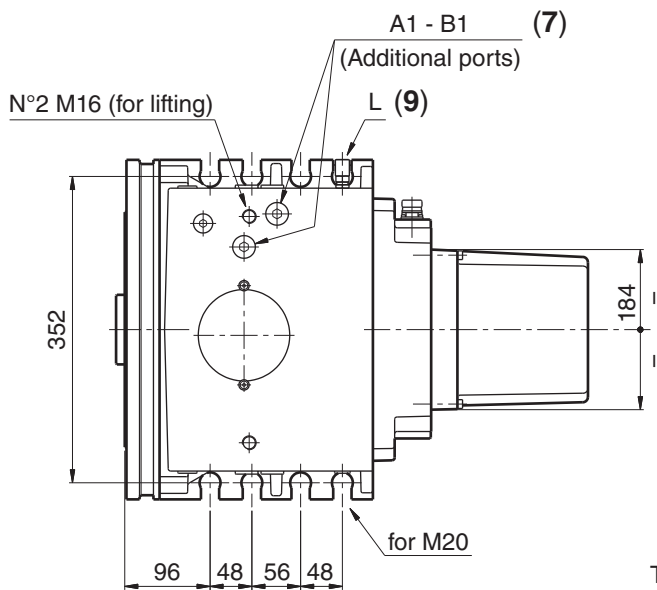
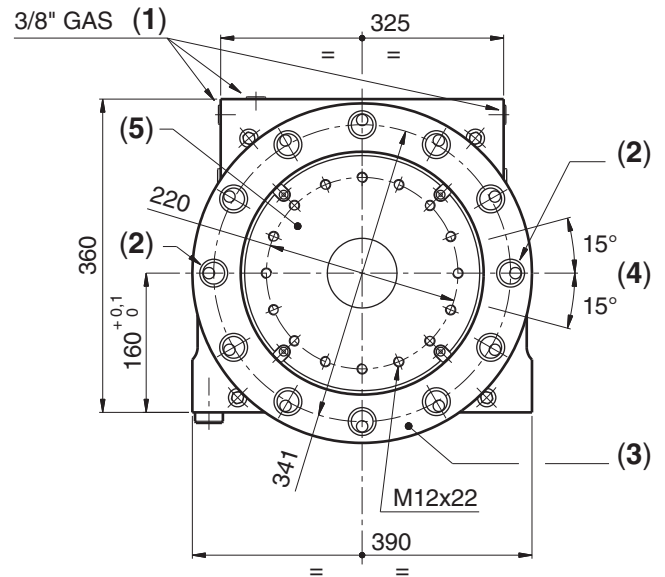
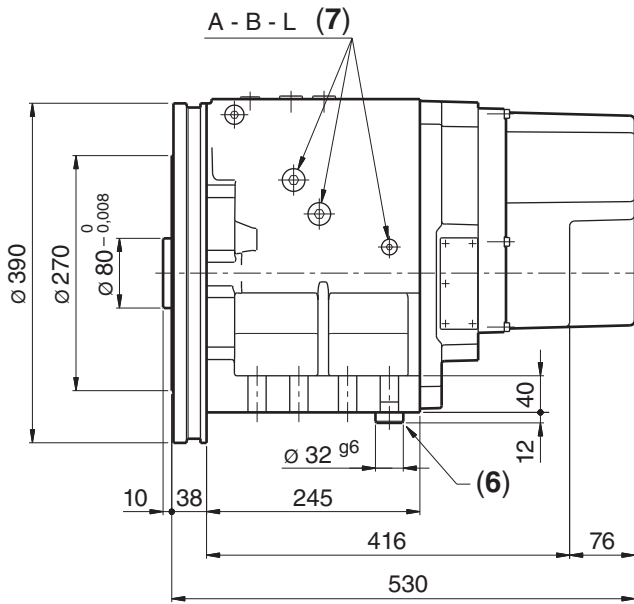

- 1) Inlet coolant positions, at choice.
- 2) Right or left coolant outlet position.
- 3) Adjustable coolant ring.
- 4) Coolant outlet displacement range.
- 5) Soft surface for boring the reference pins.
- 6) Reference pin to be positioned on both sides, at choice.
- 7) Hydraulic connections on both sides, at choice.  
For ports size see sheet 14 and 15.
- 8) Electrical connectors.
- 9) Safety valve (drain).
- 10) Reference pins between tool disc and turret.

**Note:** Main overall dimensions and fixing are interchangeable with BSV-N 320 turrets.

# SM(A)-P \*

## PNEUMATIC DIAGRAM

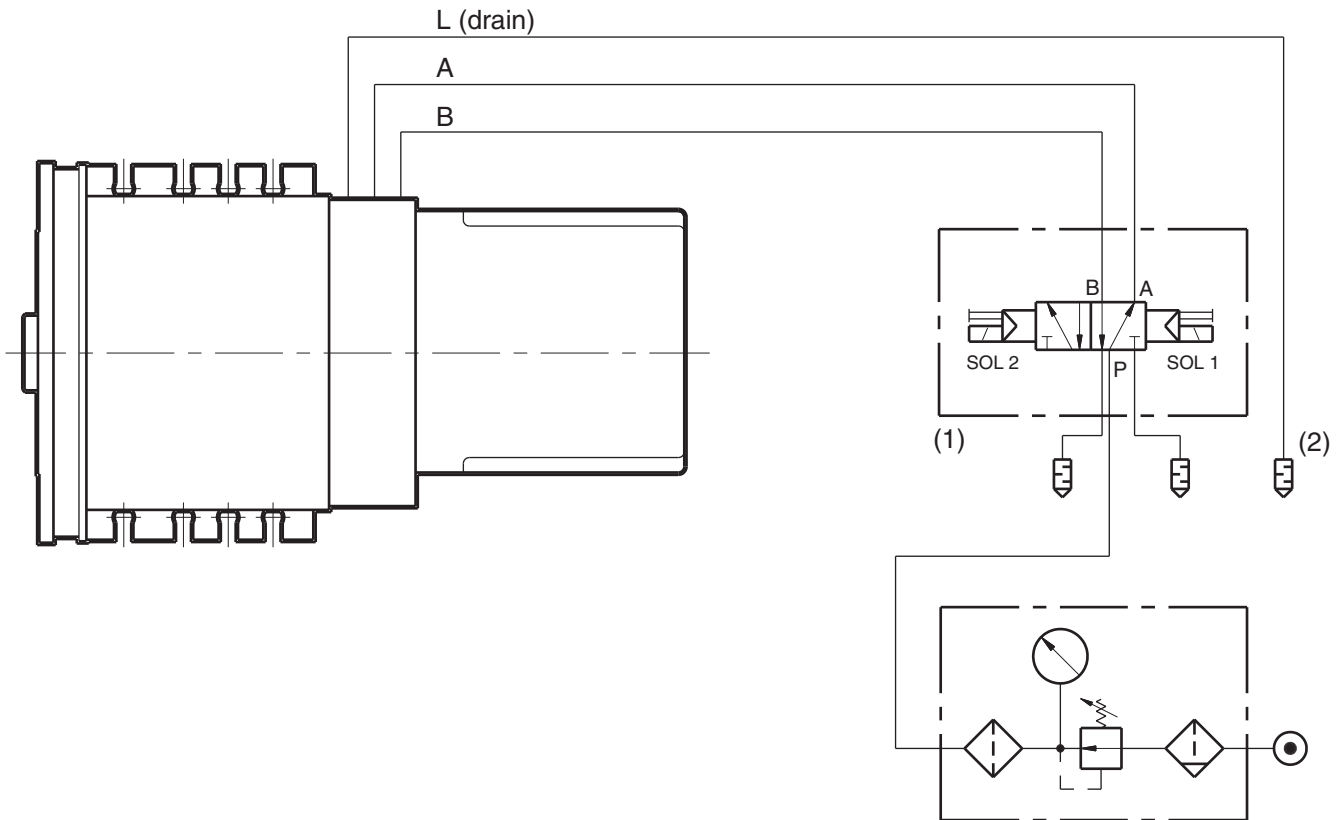

- Important:**
- (1) Use only pneumatic valve pulse type with position detent.
  - (2) The drain line must be taken out the working area of the machine.
  - (3) Suggested distance between valve and turret  $\leq 1,5$  m.

Air supply:

- Dry air (not lubricated)
- Filtering ..... 50  $\mu$ m
- Nominal pressure ..... 5<sup>+1,0</sup><sub>-0,5</sub> bar

Size	SM(A)-P	10	16	20	25
GAS connections on the turret	A - (A1)	1/8"	1/8"	1/4"	3/8"
	B - (B1)	1/8"	1/8"	1/4"	3/8"
	L - (L1)	1/8"	1/8"	1/4"	1/4"
Recommended nominal diameters for line		$\varnothing 8$	$\varnothing 8$	$\varnothing 10$	$\varnothing 12$
Air consumption for each cycle (for P= 5 bar). (unclamping + clamping)		0,30 nl/cycle	0,45 nl/cycle	1,11 nl/cycle	1,11 nl/cycle
Necessary instant flow (for P= 5 bar).		200 nl/min T= 0,10 s	300 nl/min T= 0,10 s	600 nl/min T= 0,12 s	600 nl/min T= 0,15 s

Functions	SOL 1	SOL 2
Clamping turret	+	-
Unclamping turret	-	+

# SM(A)-H \*

## HYDRAULIC DIAGRAM

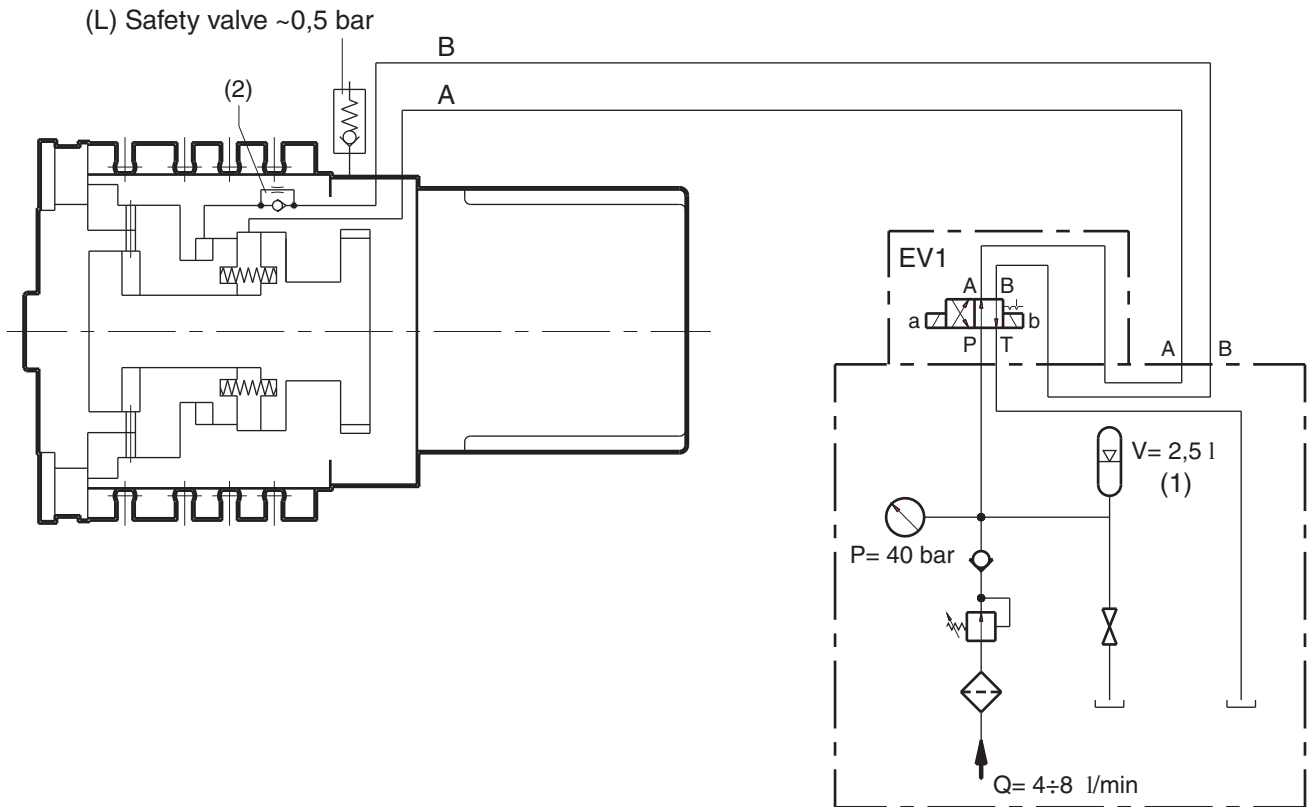

HYDRAULIC POWER PACK (Example)

(1) The accumulator's volume is according to the real pump flow rate.

Supply:

- Working pressure ..... (see beside table)
- Filtered ..... 20  $\mu$ m
- Oil viscosity ..... 32  $\div$  46 mm<sup>2</sup>/s
- Recommended oil ..... 35  $\div$  55 °C temperature

Size	SM(A)-H	10	12	16	20	25	32
Working pressure [bar]		45 $\pm$ 10%	50 $^{+5\%}_{-20\%}$	50 $^{+5\%}_{-20\%}$	50 $^{+5\%}_{-20\%}$	50 $^{+5\%}_{-20\%}$	40 $\pm$ 15%
Required oil volume							
[cm <sup>3</sup> ]	Clamping	8	18	25	49	57	163
	Unclamping	8	3,6	7	21	22	65
Needed instant flow [l/m]		3,5	8	11	16	16	24,5
	for Tb	0,15 s	0,14 s	0,14 s	0,18 s	0,22 s	0,40 s

Functions	EV1	
	sol. a	sol. b
Clamping turret	-	+
Unclamping turret	+	-

Connections on the turret							
A - (A1)	GAS	1/8"	1/4"	1/4"	3/8"	1/2"	1/2"
B - (B1)	GAS	1/8"	1/4"	1/4"	3/8"	1/2"	1/2"
L - (L1)	GAS	1/8"	1/8"	1/8"	1/4"	1/4"	1/4"

(2) For size 12, the throttler valve is not integrated inside the turret-housing but externally fastened, on the "B" port.

DN recommended nominal diameter for hydraulic line							
Lenght	$\leq$ 6 m	4	6	8	10	12	12
	> 6 m	6	8	10	12	15	15

## SM(A)- \* / series 30 WIRING DIAGRAM

The **SM\*/30** turrets are supplied with the **DDC4 Control Unit** that drives the complete indexing cycle to the position required from the machine CNC.

In the "**basic version**" the Control Unit is fitted inside the turret (only sizes 16-20-25) and the electrical connections are carried out by an external self-proof "connections box" according to the following block-diagram.

For all details and specs about electrical connections and interfacing to CNC, please refer to relevant Electrical Manual: **E.M. DDC4-\*\*-\***.

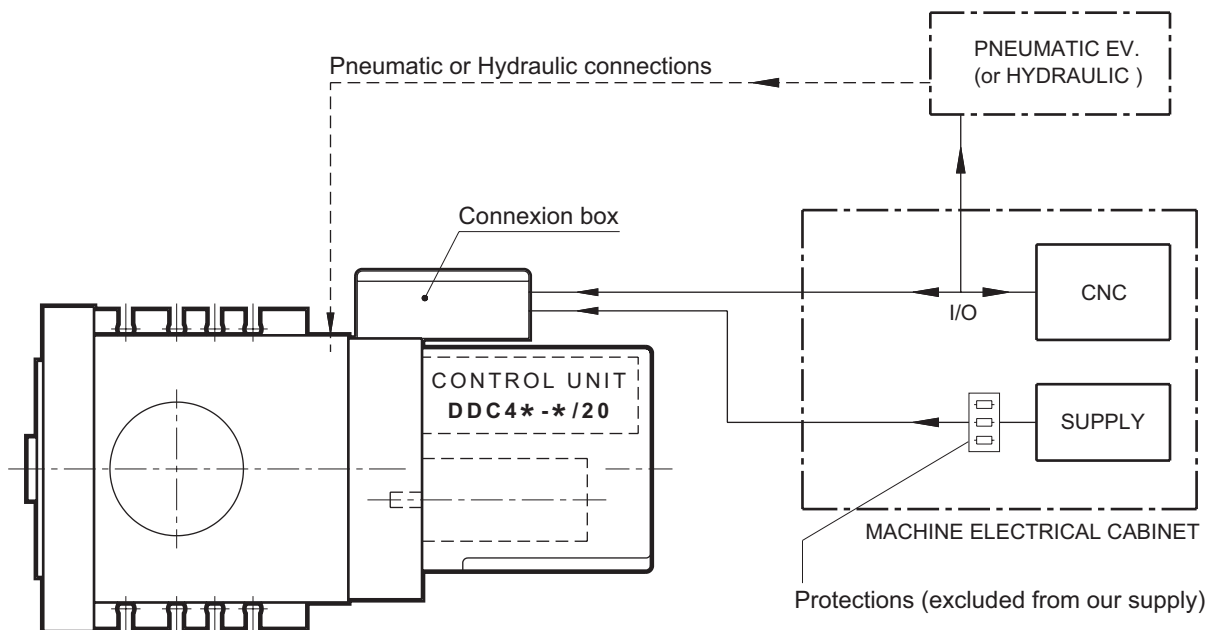

SUPPLY	SM-*	SMA-*
• Power input 3~ (1)	400VAC +15% -10% 10A max	400VAC +15% -10% 18A max
• Auxiliary supply DC	24VDC ±10% 35W	
• Frequency range	50/60Hz ±2Hz	
SPECS FOR POWER TRANSFORMER:		
• Secondary rate voltage	400 VAC ±10% - 3~	
• RATED POWER	1,0 KVA	1,2 KVA
• Max voltage drop at 10A RMS (for SM)	5%	
• Max voltage drop at 18A RMS (for SMA)	5%	
• Connections	STAR-STAR / DELTA STAR	
• Secondary voltage deviation	±2%	

INPUTS	SM-*/SMA-*
• Opto-insulated sink type	
• Voltage range	24 Vd.c. ±10%
• Current	5mA (24 Vd.c.)
<b>OUTPUTS</b>	
• Transistor MOS N.O. (source)	
• Max voltage	24 Vd.c. ± 10%
• Max current	2,0A (Power) 100mA (Signal)
• Operating temperature (turret)	0 ÷ 40°C
• Humidity	30 ÷ 95%
• Vibration:	
0,5 G RMS (continuously)	
4 G RMS (for short period)	

1) Also available in: 230 VAC-3~, 20A max. (for SM).  
230 VAC-3~, 30A max. (for SMA).



## SM(A)- \* / series 30 CONNECTION BOX

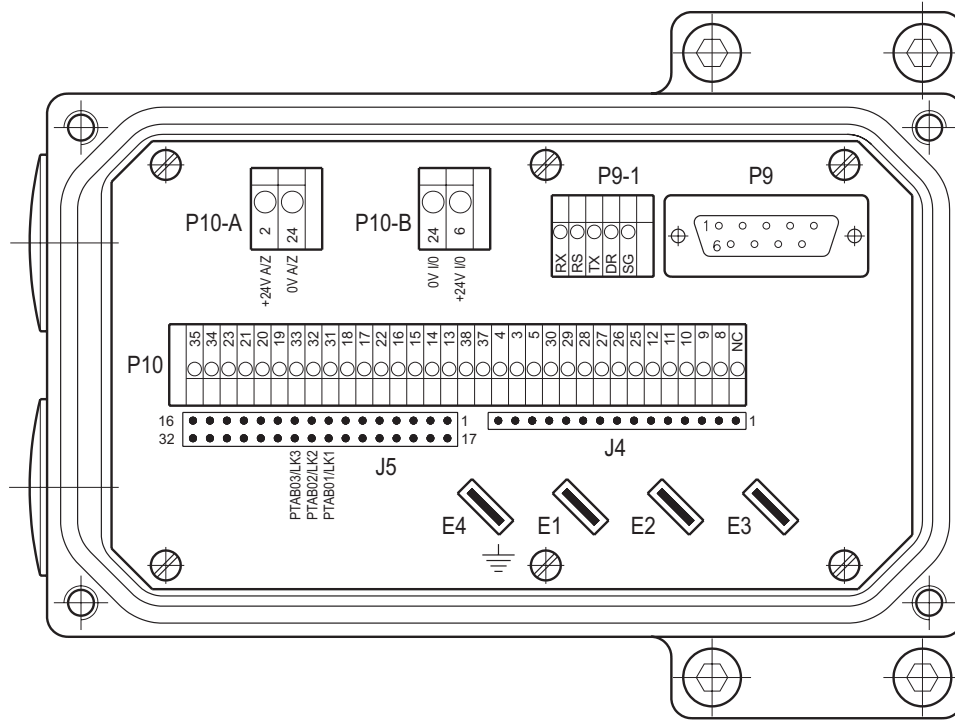

### SUPPLY CONNECTORS

		BOX SIDE TYPE
E1÷E3	AC 3 ~ Power supply	Faston 6,3 mm
E4	Ground connection	Faston 6,3 mm
P10-A	Driver supply 24 VDC	Phoenix FFKDS/V - 3,5 (spring type)
P10-B	I/O supply 24 VDC	Phoenix FFKDS/V - 3,5 (spring type)

### SIGNAL CONNECTORS

		BOX SIDE TYPE
P10	Digital INPUTS/OUTPUTS	Phoenix FFKDS/V - 2,54 (spring type) (1)
P9	RS 232 serial line	SUB-D 9 male (2)

- 1) An alternative I/O connection is available with J4 and J5 strip terminals, AMP MODU II type.
- 2) An alternative RS 232 connection is available with P9-1 spring terminal, Phoenix FFKDS/V - 2,54 type.

**IMPORTANT :** As far as the electrical wiring, the new connection box is interchangeable with the previous one, except the 220V-2~ no more required.

# SM(A)- \* / series 30 -E0 version

## WIRING DIAGRAM

The **SM\*** / series 30 turrets in "E0" version are supplied with the **DDC4 Control Unit** for Remote Installation inside the machine electrical cabinet (only for sizes 12-16-20-25). The turret-side electrical connections are carried-out by terminal boards, inside the rear cover.

**IMPORTANT** : In the machine electrical cabinet proper electrical protection devices must be foreseen. (i.e. fuses).

For all details and specs about electrical connections and interfacing to CNC, please refer to relevant Electrical Manual for remote installation : **E.M. DDC4-\*\*-\***.

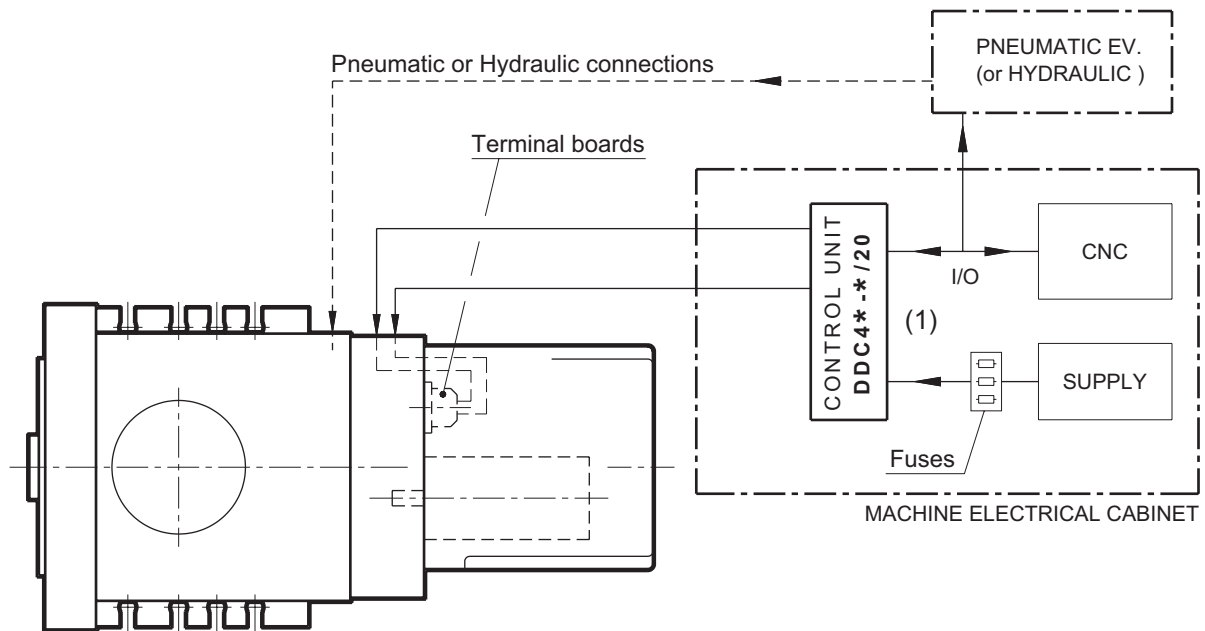

- (1) Included in our supply : **DDC4-\* Control Unit.**  
Excluded from our supply : Fuses and whatever not clearly mentioned.

### CONTROL UNIT OVERALL DIMENSIONS

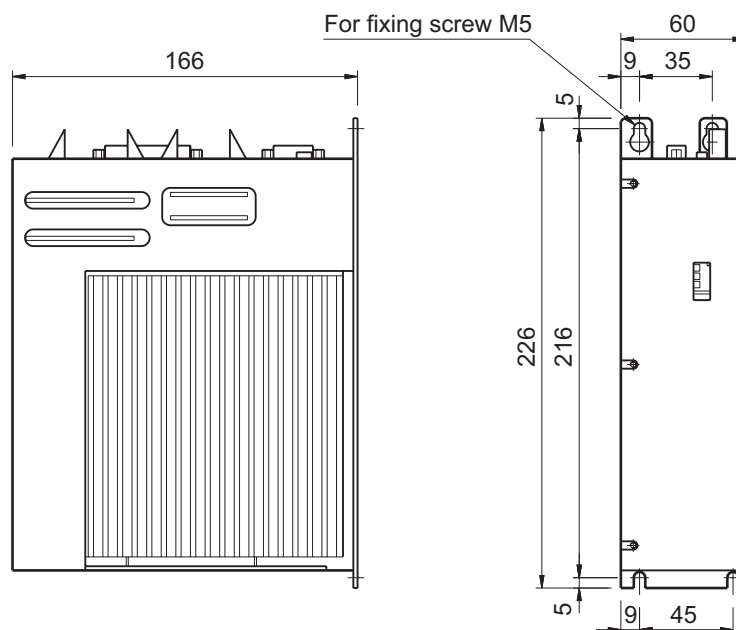

**NOTE:** Foresee at least 20 mm of free space on both sides and at least 100 mm above and below to allow connections and cooling airflow.

# SM(A)- \* / series 30 -E0 version

## HOW TO CONNECT

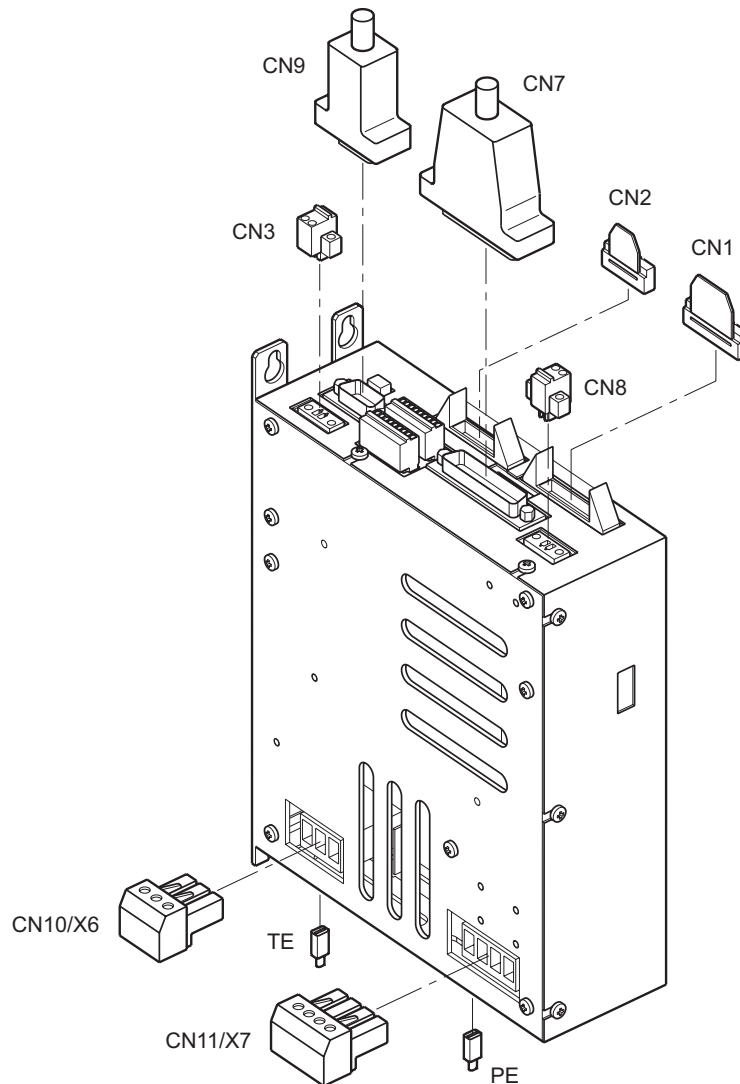

### POWER CONNECTORS

		CABLE SIDE	
CN10/X6	AC supply 3 ~	PC4/3-ST-7,62	
CN11/X7	Motor power	Phoenix contact PC4/4-ST-7,62	
TE/PE	Ground connections	Faston 6,3 mm	(1)

### SIGNAL CONNECTORS

		CABLE SIDE	
CN1	Digital OUTPUTS	20 pins/2 Rows IDC-2,54 mm female DIN 41651	(1)
CN2	Digital INPUTS	16 pins/2 Rows IDC-2,54 mm female DIN 41651	(1)
CN3	24VDC for I/O section	Phoenix contact FK-MCP 1,5/2-STF-3,5	
CN8	24VDC for driver section	Phoenix contact FK-MCP 1,5/2-STF-3,5	
CN7	Signal to/from turret	SUB-D 25 female DIN 41652	(1)
CN9	RS232 serial connection	SUB-D 9 female DIN 41652	(1)

(1) Not supplied

# SM(A)- \*

## ELECTRICAL CONNECTORS

The **SM\*** turrets can be supplied with industrial connectors on the turret-side for a quick and water proof plug in. This solution is already used on the last born turrets, as **SM\*-10** and **SM-H-32**, which **DDC4 Control Unit** for Remote Installation inside the machine electrical cabinet. Anyway, industrial connectors can be required on the current **SM\*/30-E0** as an optional supply.

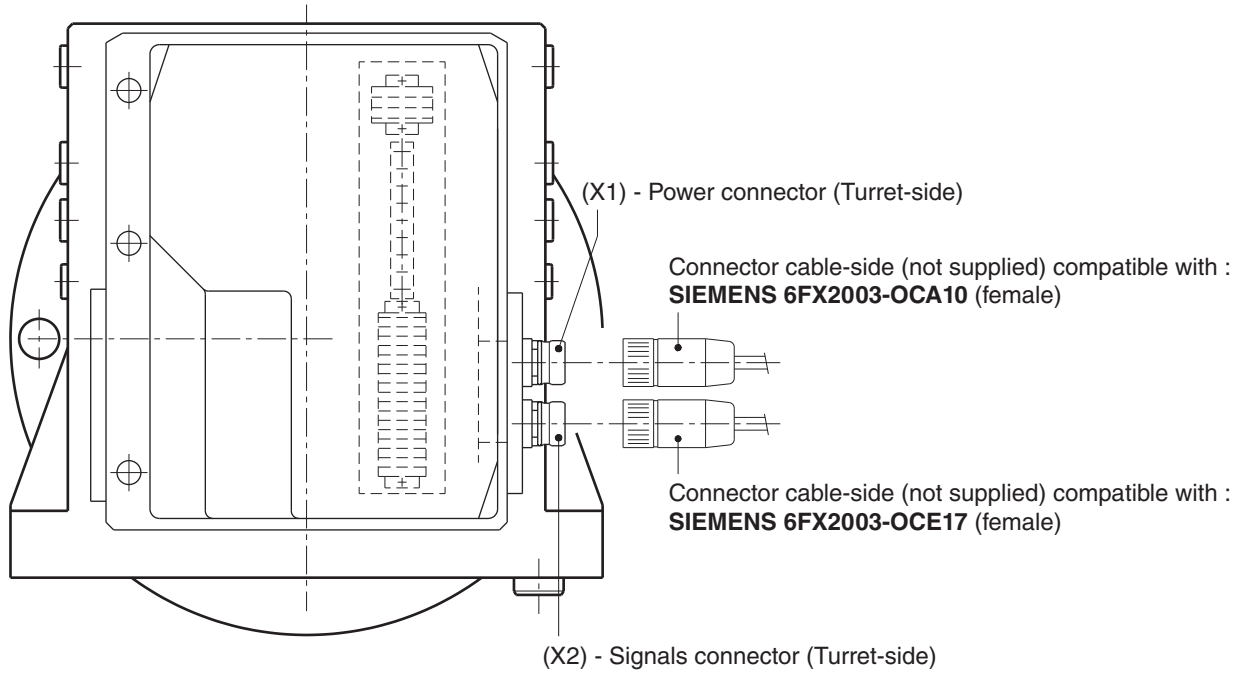

### Connectors (Turret-side)

(X1) **POWER: AFEA 06 CMRSN 000 male**  
Panel mount socket for male contacts.

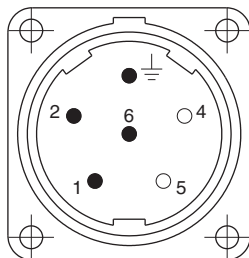

- View from mating side
- Contacts 4 and 5 not used.

(X2) **SIGNAL: SFOA 17A MREN 000 male**  
Panel mount socket for male contacts (n° 17).

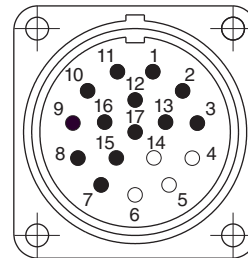

- View from mating side.
- Contacts 4-5-6-14 not used. (1)

(1) For SM-H-32 turret, the contact 15 is not used.

## "PA" VERSION TURRETS (with axial through-bore)

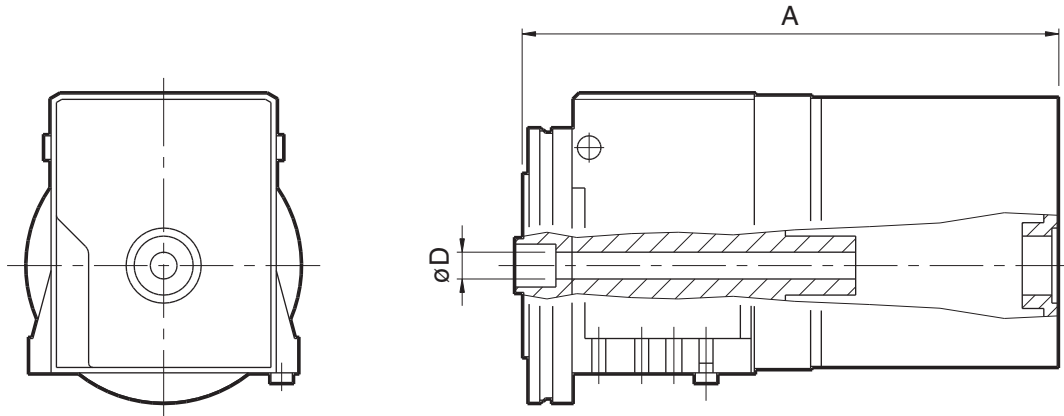

Turret size	SM 12	SM(A) 16	SM(A) 20	SM(A) 25	SM 32
$\varnothing D$	22	22	32	32	55
A	424	458	499	517	497

## OPTIONAL FEATURES

Optional devices are available on SM\* turrets for different specific applications, like:

- Hydraulic, or pneumatic, connections through the turret (with "PA" version) for supply automatic clamping/unclamping of modular tools, clamping devices, steady rests, etc.
- Tool monitoring systems: pocket solution or sensor plate type
- Measuring probe
- High pressure coolant applications

For further information please contact our Technical Department.

"SM\*" turrets have been designed for modular fitting of different driven tool systems

**SM\*-DT**

- With **ODT-N** driven tool device.
- Tool coupling according to DIN 1809.
- Tool disc with **axial** seats.
- Front machining.

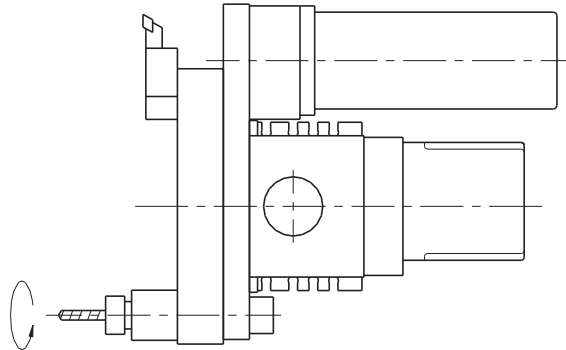

**SM\*-MDT**

- With **MDT** driven tool device.
- Tool coupling according to DIN 5480 / 5482
- Tool disc with **axial** seats.
- Front machining.

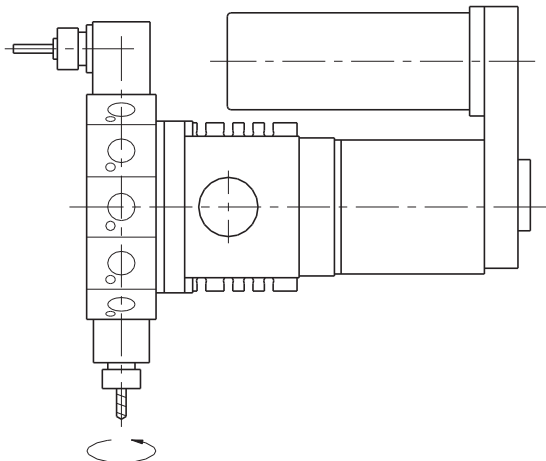
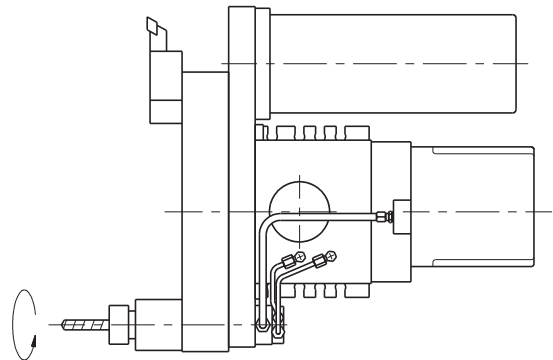

**SM\*-TR**

- With **IDT-R** driven tool device.
- Tool disc with **radial** seats.
- Front machining.

**SM\*-TR/BM**

- With **IDT-R/BM** driven tool device.
- Offset tool disc with **radial** seats.
- Front and **back machining** for **sub-splinde** machines.

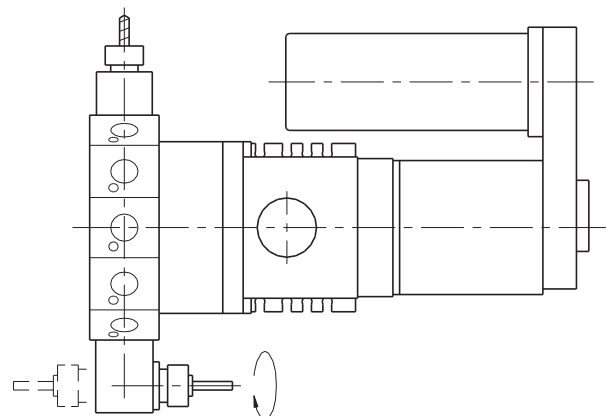

For further information please contact our Technical Dept.

# SM(A)- \*

## IDENTIFICATION CODE

### SM \* - \* - \* - \* - \* - \* /3\* - \* - \*

INDEXING SYSTEM	CODE
Fast	—
Superfast	<b>A</b>

CLAMPING SYSTEM	CODE
Pneumatic	<b>P</b>
Hydraulic	<b>H</b>



SIZE	CODE
100	<b>10</b>
120	<b>12</b>
160	<b>16</b>
200	<b>20</b>
250	<b>25</b>
320	<b>32</b>

AXIAL THROUGH BORE	CODE
Without (Standard)	—
With (Optional)	<b>PA</b>

#### OPTIONALS

CODE	SUPPLY VOLTAGE
400	400 VAC - 3 ~
230	230 VAC - 3 ~

SERIE	30 ÷ 39	(1)
-------	---------	-----

CODE	VERSION
—	Right 
<b>S</b>	Left 

POSITIONS	CODE
Nr. 8 Pos.	<b>8</b>
Nr. 12 Pos.	<b>12</b>

(1) From 30 to 39 the performance and the overall dimensions do not change.

**DIPLOMATIC AUTOMATION S.r.l.**  
20025 LEGNANO (MI) - ITALY  
P.LE BOZZI, 1  
PHONE 0331/472111  
FAX 0331/455161



**DIPLOMATIC**  
AUTOMATION

e-mail: [info@diplomatic.it](mailto:info@diplomatic.it)

come visit Diplomatic homepage:  
[www.diplomaticautomation.com](http://www.diplomaticautomation.com)