

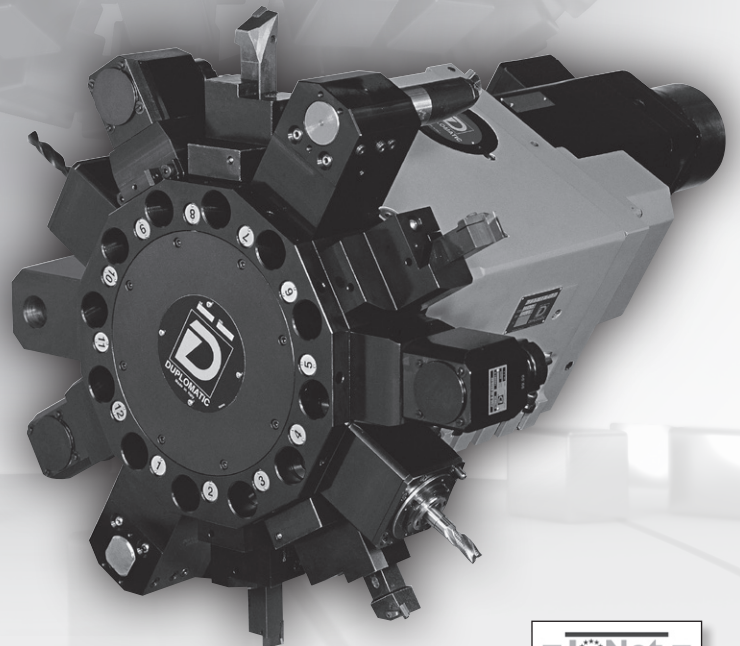

DUPLOMATIC
AUTOMATION

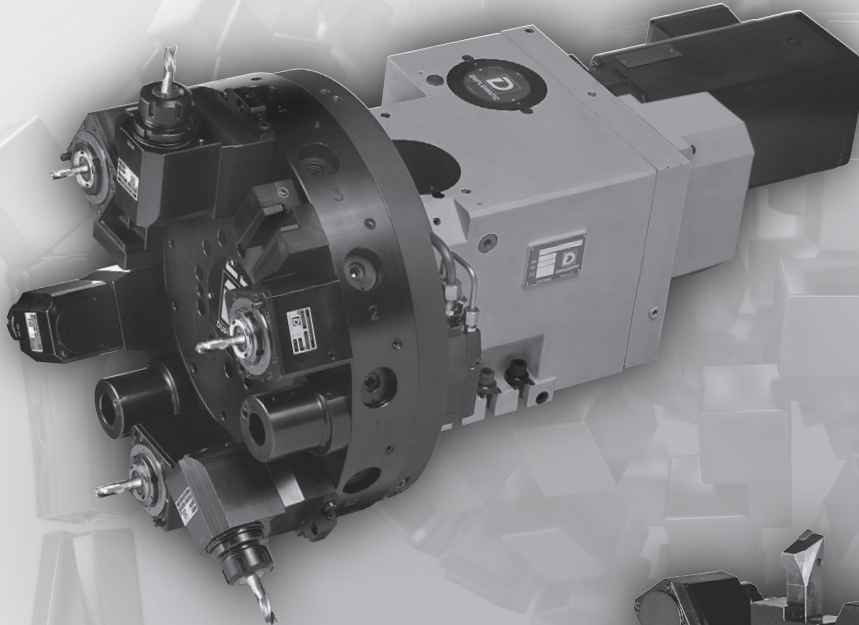

SM-B* series 30

ONE ONLY SERVOMOTOR
TURN-MILL TURRETS



TECHNICAL INFORMATION

I.T. 6445

GB ISSUED **07-09**

The data given in the I.T. are subject to technical modifications without notice.

SM-B * / series 30

MAIN FEATURES

SM-BA * /30

AXIAL VERSION

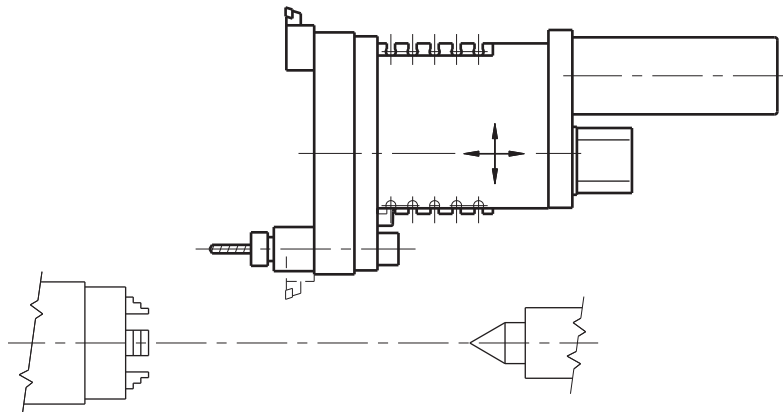

SM-BR * /30

RADIAL VERSION

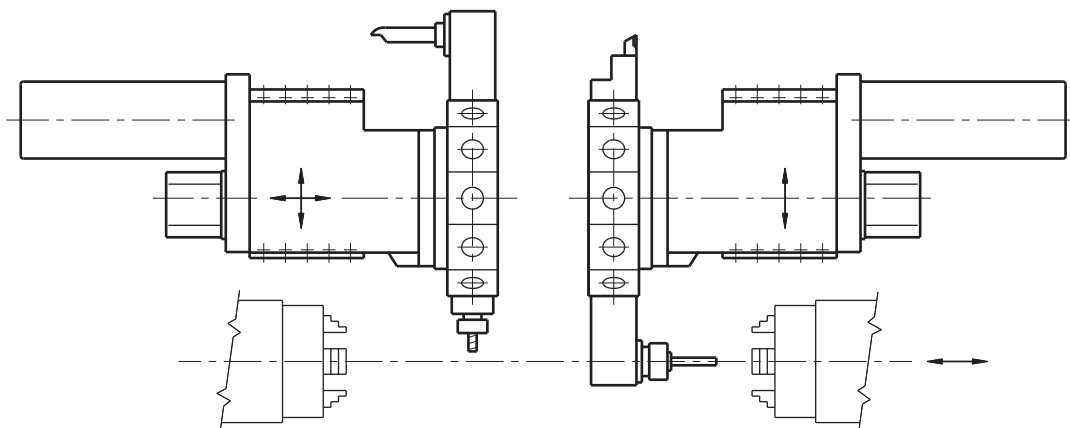

- Super fast indexing times.
- Very high rigidity and loading capacity.
- Clamping/Unclamping system hydraulically operated.
- One only servomotor drives the turret rotation and the rotating tools.
- All the disc stations can be used for rotating tools and only the working tool is driven without dead times.
- Pressurizing air and centralized lubrication functions for driven tool system's long life.

DRIVEN TOOL TURRET

AXIAL VERSION:

SM-BA * C
SM-BA * F (1)

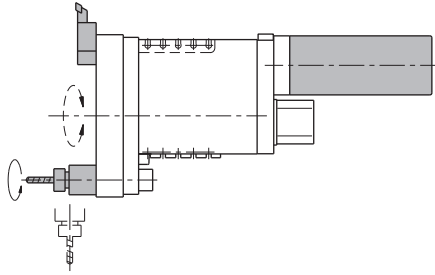

RADIAL VERSION (COMPACT FORM):

SM-BR * C
SM-BR * F (1)

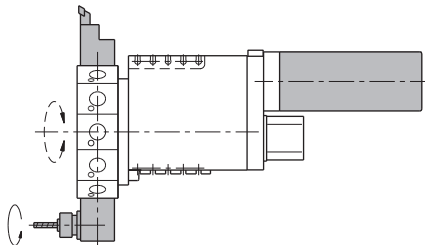

RADIAL VERSION:

SM-BR *

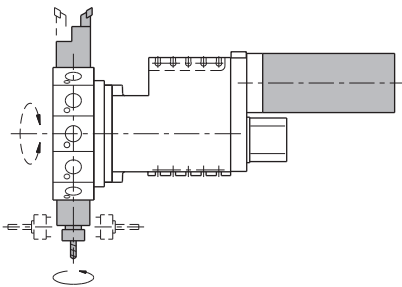

STATIC TOOL TURRET

SM-B- * C
SM-B- * F (1)

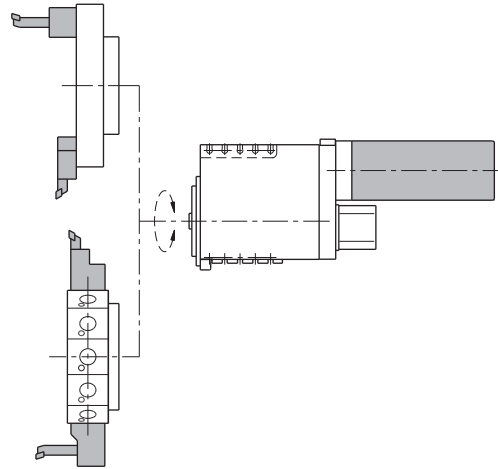

SM-B-*

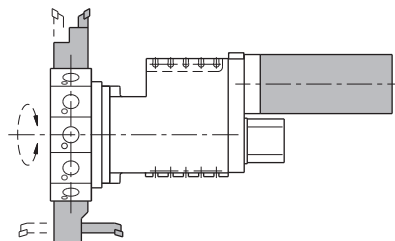

(1) "C" or "F" identify the turret versions with compact housing.
According to the turret sizes, it is available a double centerline height:
"C" standard height.
"F" bigger height.

Turret			SM-B *					
			12		16		20	25
Sizes			12	16 ⁽⁴⁾	12	16 ⁽⁴⁾	12	12
Tool stations			12	16 ⁽⁴⁾	12	16 ⁽⁴⁾	12	12
Inertia of transportable masses	(1)	Kgm ²	1,25	2,2	2,5		5,0	10
Positioning times:	(2)		0,12	0,14	0,14	0,13	0,16	0,20
Indexing time (including acc. / dec.)	one step	s	(30°)	(22,5°)	(30°)	(22,5°)	(30°)	(30°)
Rotation time only		s	0,06	0,045	0,06	0,045	0,06	0,08
			(30°)	(22,5°)	(30°)	(22,5°)	(30°)	(30°)
(T _{sb}) Unclamping or (T _b) clamping time	(2)	s	0,14		0,14		0,18	0,22
Indexing frequency	(3)	Cycle/min	20		18		15	12
Indexing accuracy		Deg°	±4"		±4"		±4"	±4"
Repeatability accuracy		Deg°	±1,6"		±1,6"		±1,6"	±1,6"
Hydraulic working pressure	+ 5% - 20%	bar	50		50		50	50
Required oil volume		cm ³ /cycle	25		37		76	86
Mass (including tool disc)		Kg	~ 80	~ 90	~ 150		~ 240	~ 310
Ambient temperature range		°C	5 ÷ 40		5 ÷ 40		5 ÷ 40	5 ÷ 40
Coolant supply:								
• Costant flow	(Filtering ≤ 150 μm)							
• Pressure cut-off during turret rotation:		bar	7		7		7	7
– Low pressure	(Filtering ≤ 150 μm)	bar	14		14		14	14
– Medium pressure (option)	(Filtering ≤ 50 μm)	bar	30		30		30	30
Max motor speed		RPM	2.000	1.400	2.000	1.400	2.000	1.600
Transmission ratio		τ	1:24	1:16	1:24	1:16	1:24	1:24

(1) Larger inertia values can be applied with increased indexing times.

(2) Conditions:

- Proper Servomotor.
- Hydraulic supply properly sized.
- Without dead-times caused by machine CNC.

(3) Reduced values according to the tool drive use.

(4) Only for SM-BR.

OPTION: For fluids into the tool disc (i.e. air, hydraulic oil or high-pressure coolant), please ask our Technical Department.
P max = 100 bar.

Tool drive		SM-B *			
Size		12	16	20	25
Max torque [S3 – 40% 10 min.]	(5) Nm	14	28	40	66
Max speed at the spindle	RPM	6.000	5.000	4.000	3.000
Transmission ratio	τ	1:1	1:1	1:1	1:1
Coupling DIN 5480	(6)	14 x 0,8	16 x 0,8	20 x 0,8	24 x 1,25

- (5) These values are valid for free-shock operations.
In case of interrupted-cut or other shock-operations, a reduction of these values up to 50% must be considered.
- (6) Use only driven tool-holders with DIN 5480 coupling and zero detent system.

Motor (optional) (7) (8)

SIEMENS	AC servomotor	1FT 6064 ...	1FT 6084 ...	1FT 6086 ...	1FT 6105 ...
FANUC	AC splinde motor	$\alpha 1,5$	$\alpha 2$	$\alpha 3$	$\alpha 6$

- (7) Other motors on request.
(8) Protection **IP67** on shaft side.

LOADING DATA

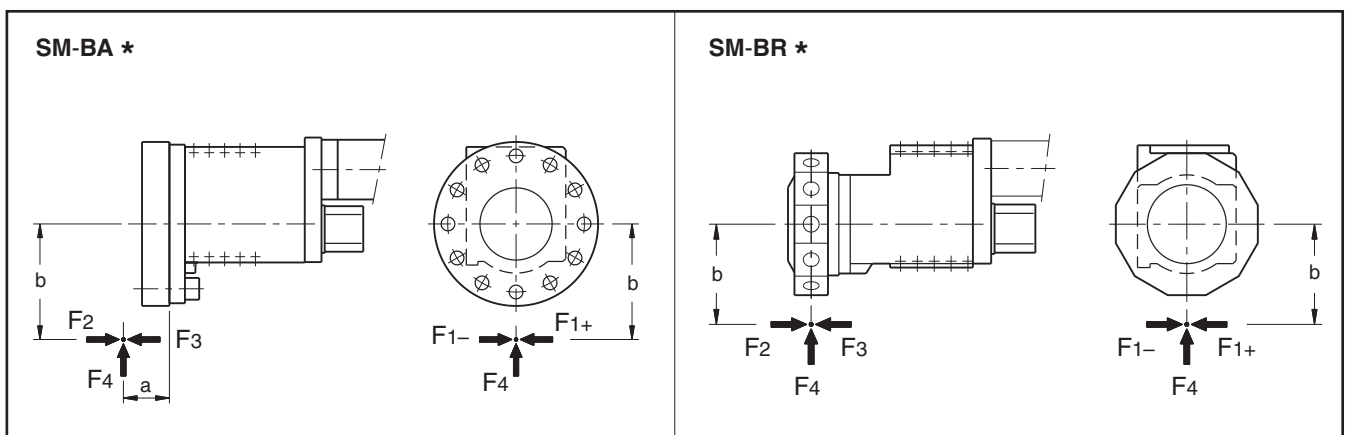

			SM-B *			
			12	16	20	25
Max. tangential torque	F1xb	Nm	950	1.800	3.600	7.200
Max. tilting torque (to push)	F2xb	Nm	1.500	2.500	5.200	10.000
Max. tilting torque (to lift)	F3xb	Nm	1.250	2.200	4.500	8.000
Max. radial force (9)	F4	N	10.000	14.000	24.000	35.000
	F4 x a	Nm	1.250	2.200	4.500	8.000
Unbalancing torque		Nm	16	35	65	125

- (9) For SM-BA the max radial force "F4" depends on the lever distance "a".
(10) Safety factor $\geq 1,3$.

SM-BA * / series 30

SIZES AND DIMENSIONS

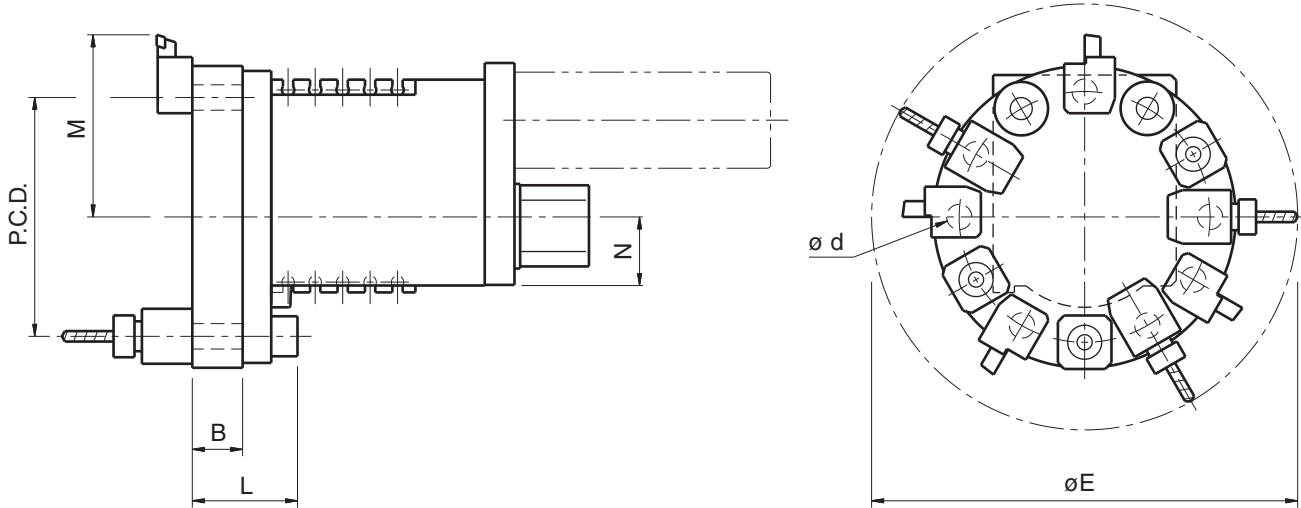

Size	SM-BA	12	16	20	25
Toolholder size	DIN 69880 - ød	25	30	40	50
Tool disc size	P.C.D. (1)	270	340	340 370	420
	B	58	67	75	93
	ø E (2)	430	520	560 590	660
	M (2)	185	230	245 260	305
	L	128	138	155	178
	N	68	82	100	125

[mm]

- (1) On request, tool discs with different dimensions are available.
 (2) Indicative values. They depend from tool-holders.

SM-BR * / series 30

SIZES AND DIMENSIONS

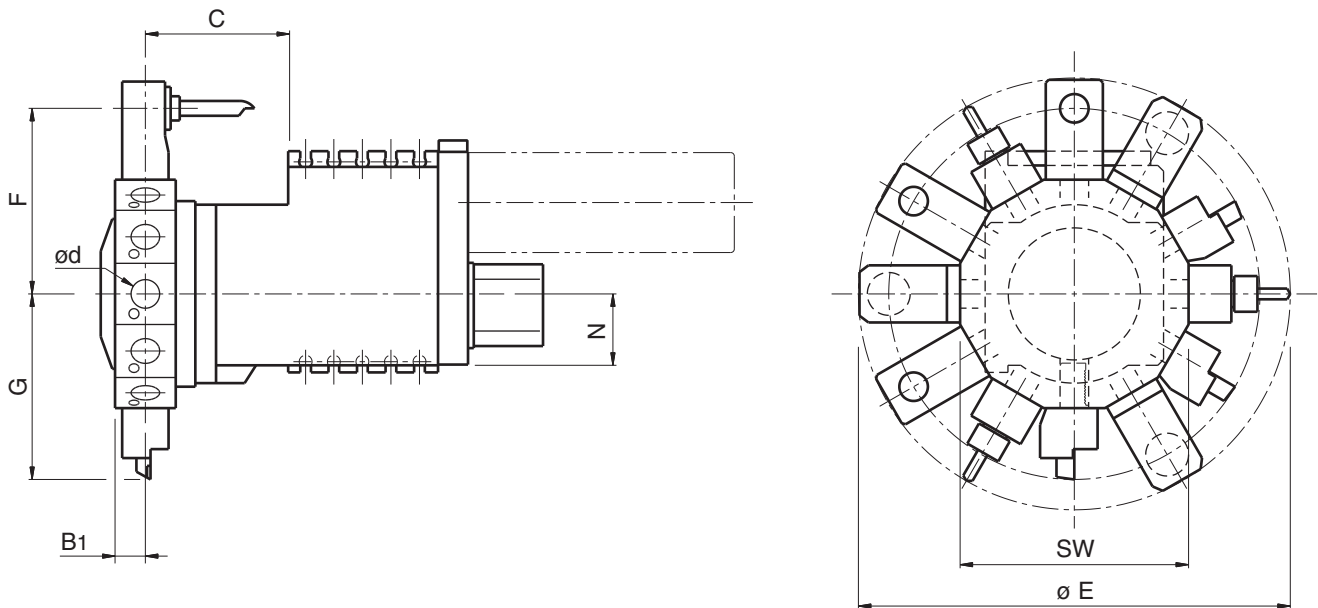

Size	SM-BR	12	12/16	16	16/20	20	25
Toolholder size	DIN 69880 - ød	25		30		40	50
N° of positions		12	16	12	16	12	12
Tool disc size	SW min. (1)	220	300	270	340	320	380
	B1	46		54		66	74
	C	124	—	160	—	200	250
	ø E (2)	430	510	522	595	610	720
	F (2)	185	225	220	255	260	310
	G (2)	185	225	220	255	260	310
	N	68	—	82	—	100	125

[mm]

- (1) On request, tool discs with different dimensions are available.
 (2) Indicative values. They depend from tool-holders.

SM-BA * / series 30

TURRET AND DISC VERSION

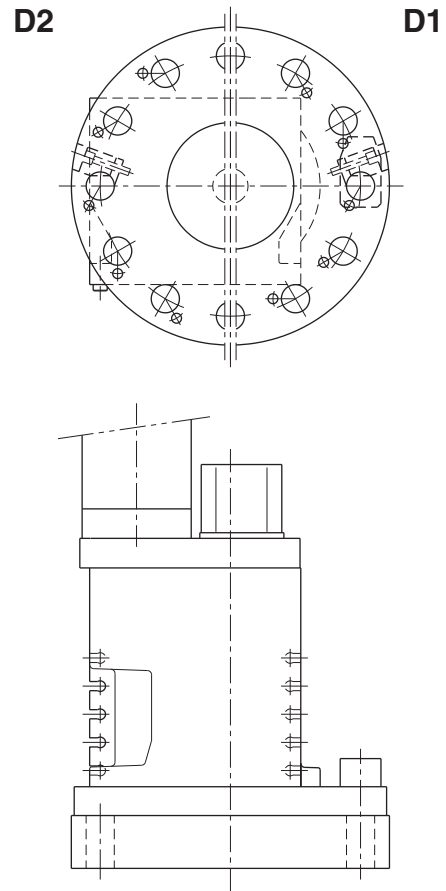
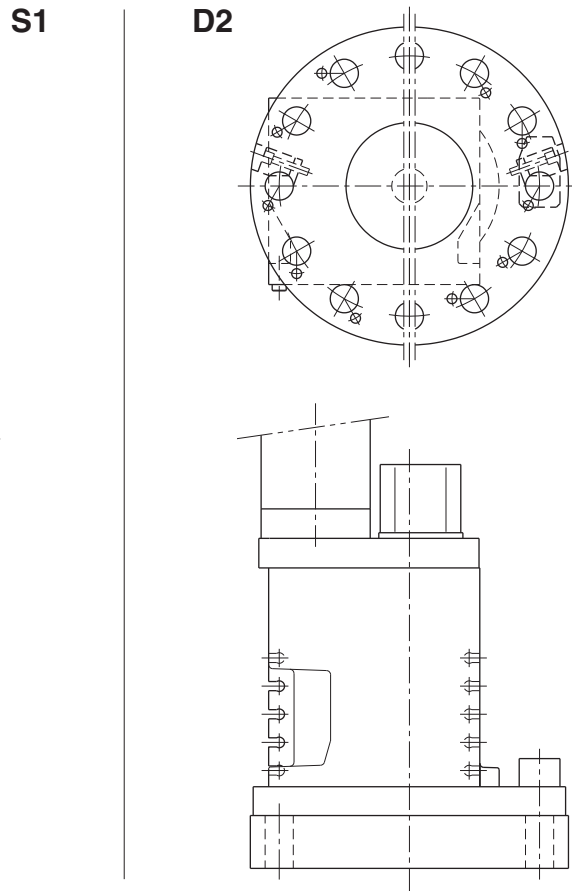
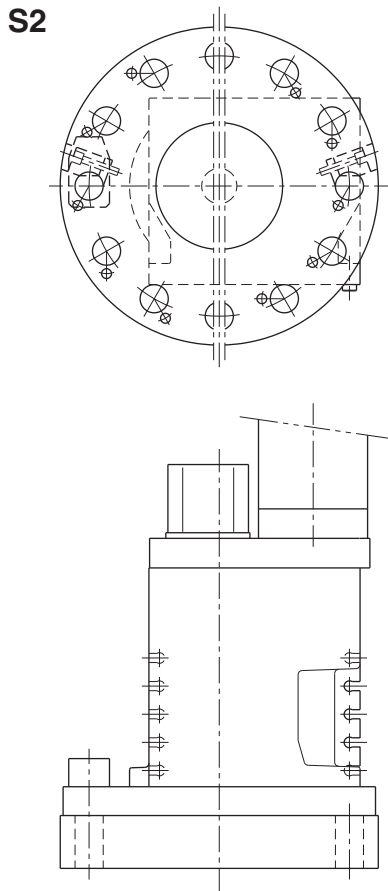

D1

	S2	S1	D2	D1
Turret	Left	Left	Right	Right
Tool disc	Left	Right	Left	Right

MOTOR POSITION

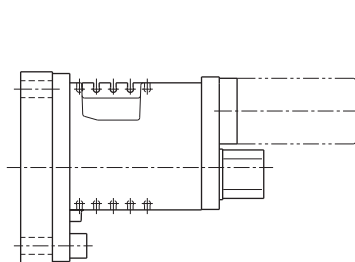

STANDARD

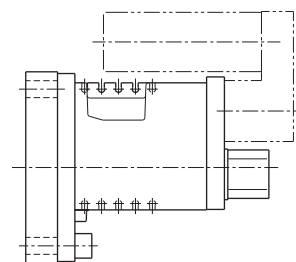

OPTIONAL
("W" version)

WORKING POSITION

- STANDARD: at "3 o'clock" for right turrets.
at "9 o'clock" for left turrets.
- Different working positions, on request.

SM-BR * / series 30

TURRET AND DISC VERSION

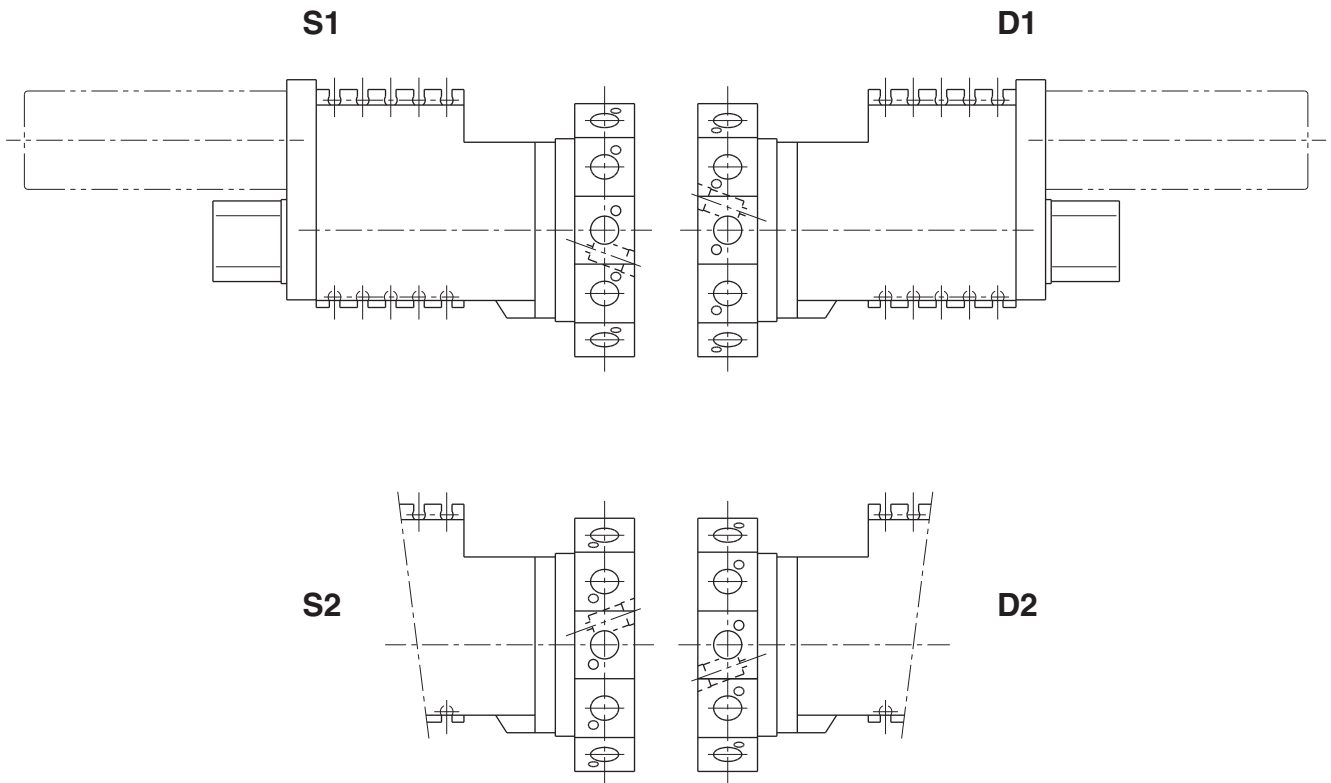

	S2	S1	D2	D1
Turret	Left	Left	Right	Right
Tool disc	Left	Right	Left	Right

MOTOR POSITION

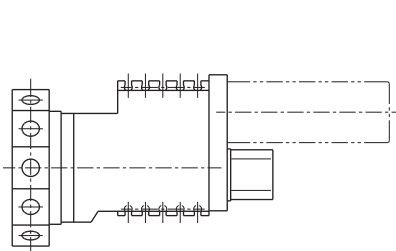

STANDARD

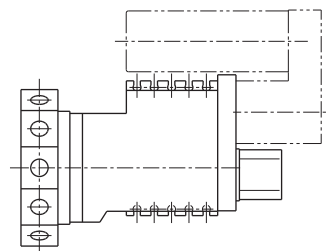

OPTIONAL
("W" version)

WORKING POSITION

- STANDARD: at "3 o'clock" for right turrets.
at "9 o'clock" for left turrets.
- Different working positions, on request.

SM-BA 12C / series 30

OVERALL DIMENSIONS

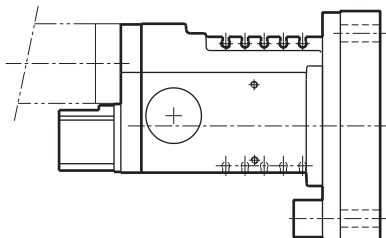
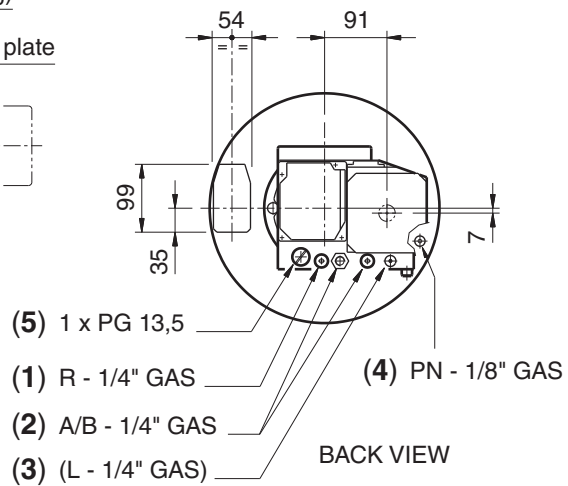
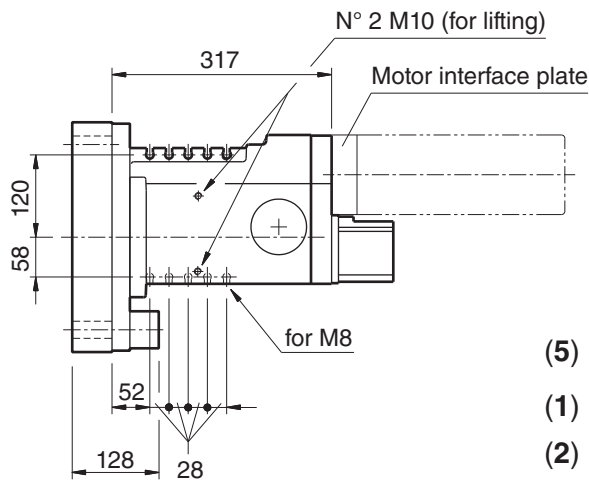
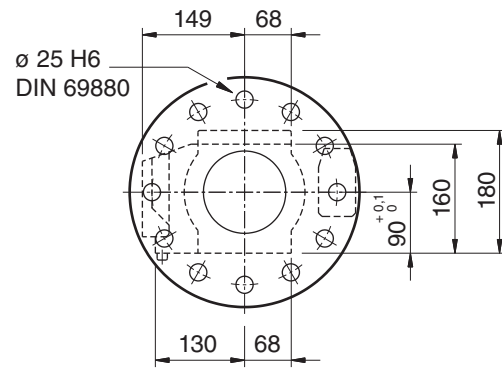
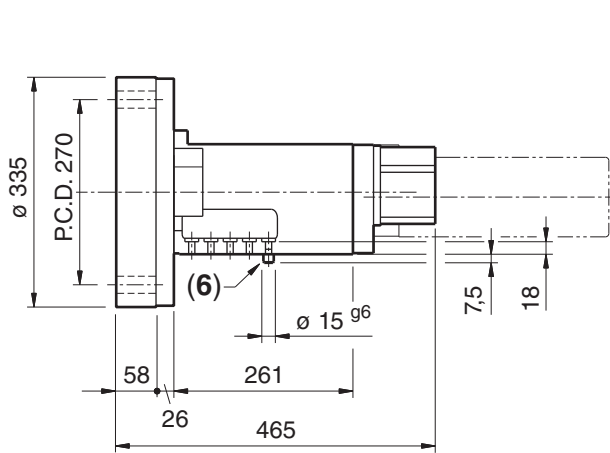

LEFT VERSION: overall dimensions are mirror-image

- 1) Inlet coolant positions.
- 2) Hydraulic connections.
- 3) Safety valve (drain).
- 4) Pressurizing air inlet.
- 5) Electrical connection.

Important: the connection cable must be provided with fittings and gaskets in order to avoid penetration of water into the turret.

- 6) Reference pin.

SM-BR 12 / series 30

OVERALL DIMENSIONS

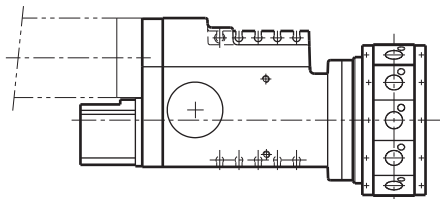
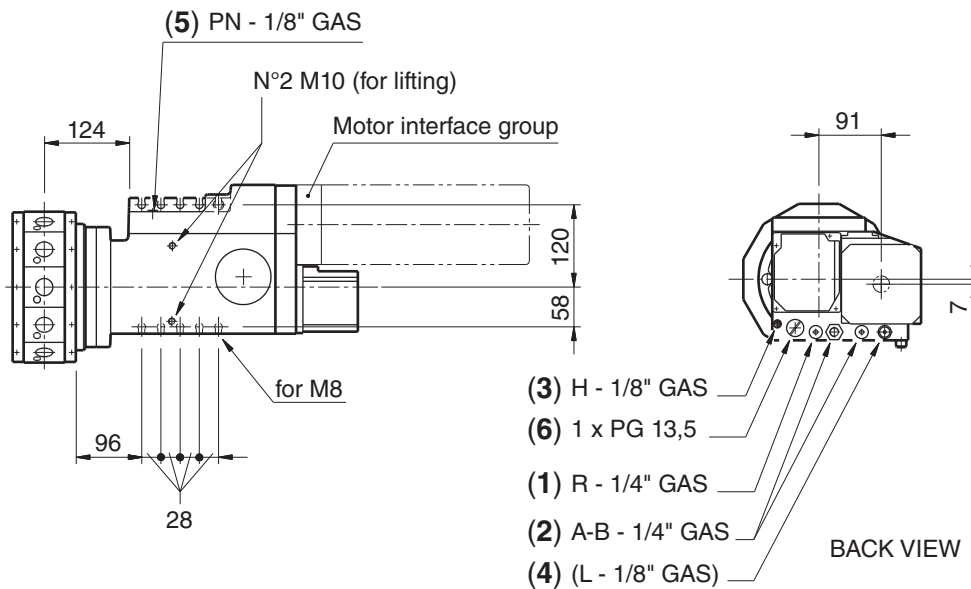
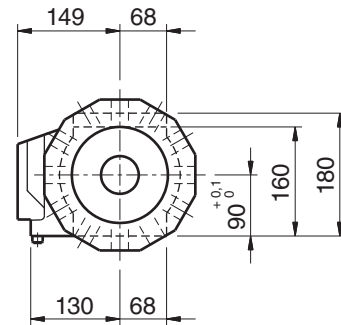
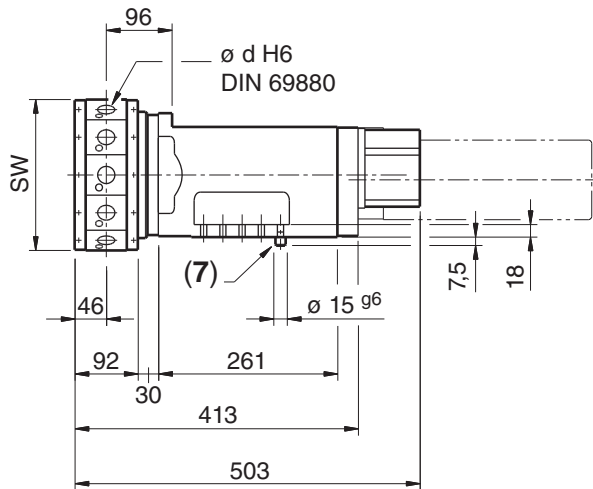

LEFT VERSION: overall dimensions are mirror-image

- 1) Inlet coolant positions.
- 2) Hydraulic connections.
- 3) Centralized lubrication inlet.
- 4) Safety valve (drain).
- 5) Pressurizing air inlet.
- 6) Electrical connection.

Important: the connection cable must be provided with fittings and gaskets in order to avoid penetration of water into the turret.

- 7) Reference pin.
- 8) For overall dimensions of the "Compact" version, ask for relevant drawing.

Disc type	ød	SW
12 pos.	25	220
16 pos.	25	300

SM-BA 16C / series 30

OVERALL DIMENSIONS

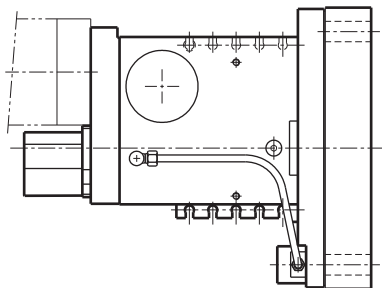
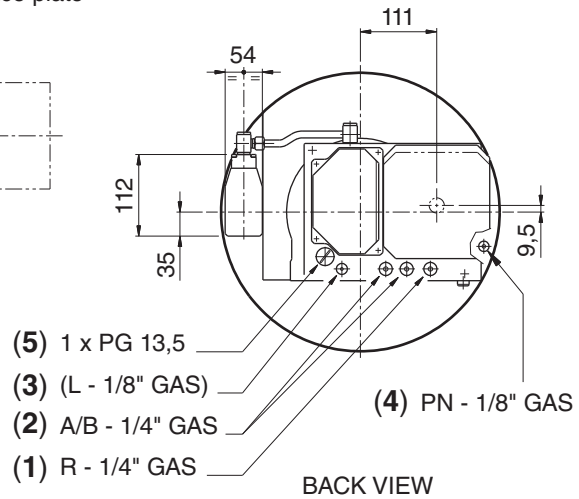
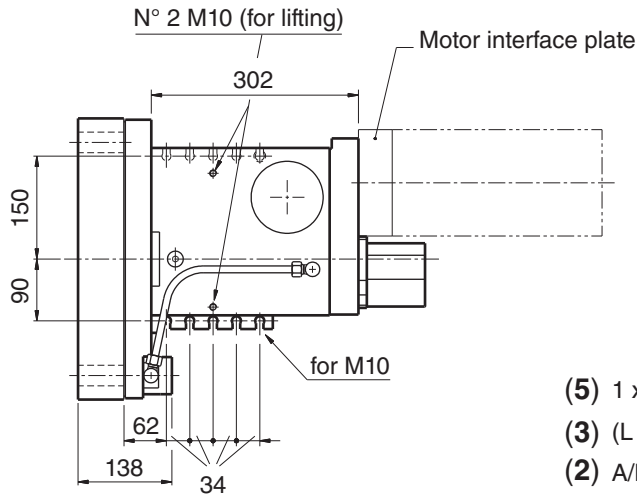
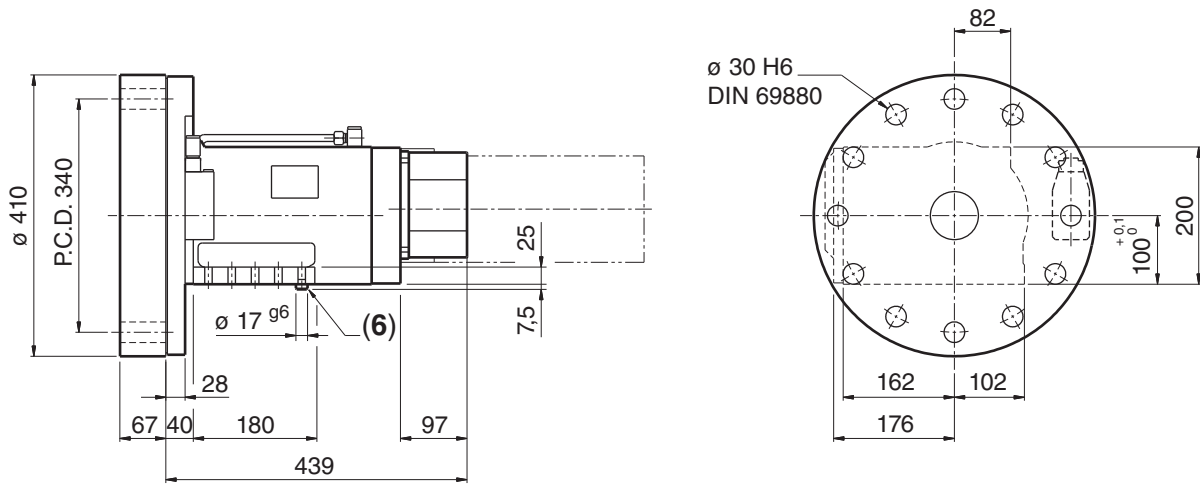

LEFT VERSION: overall dimensions are mirror-image

- 1) Inlet coolant positions.
- 2) Hydraulic connections.
- 3) Safety valve (drain).
- 4) Pressurizing air inlet.
- 5) Electrical connection.

Important: the connection cable must be provided with fittings and gaskets in order to avoid penetration of water into the turret.

- 6) Reference pin.

SM-BR 16 / series 30

OVERALL DIMENSIONS

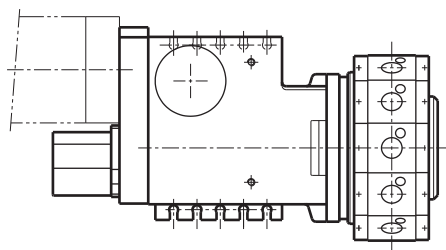
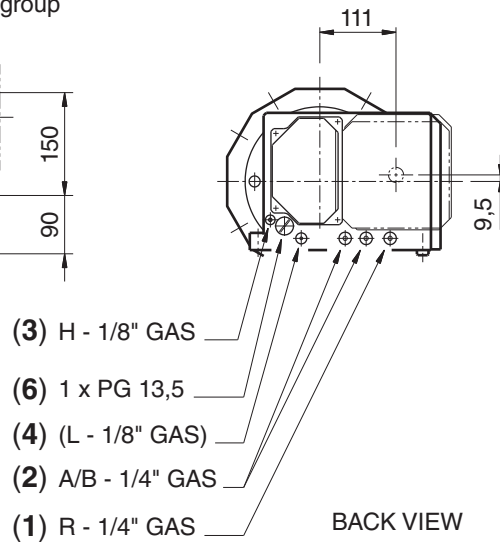
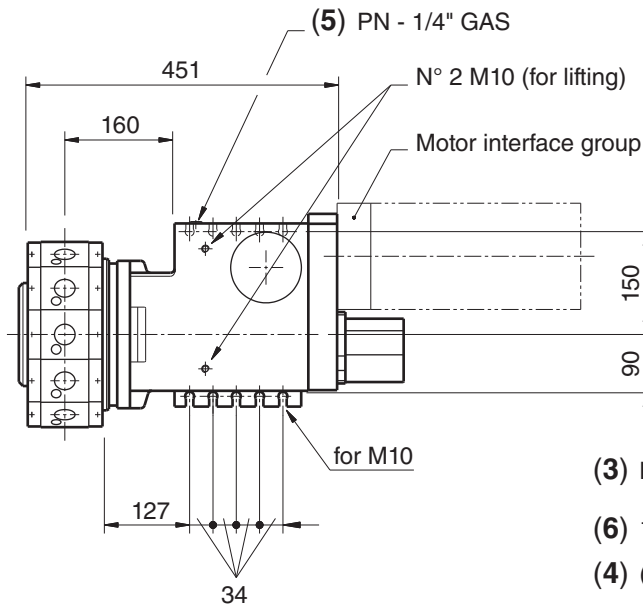
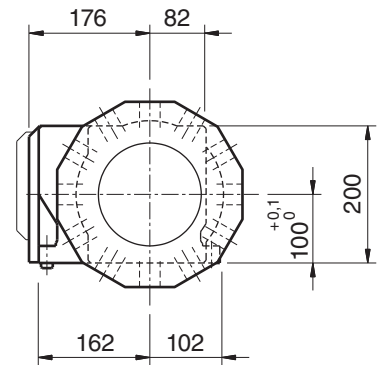
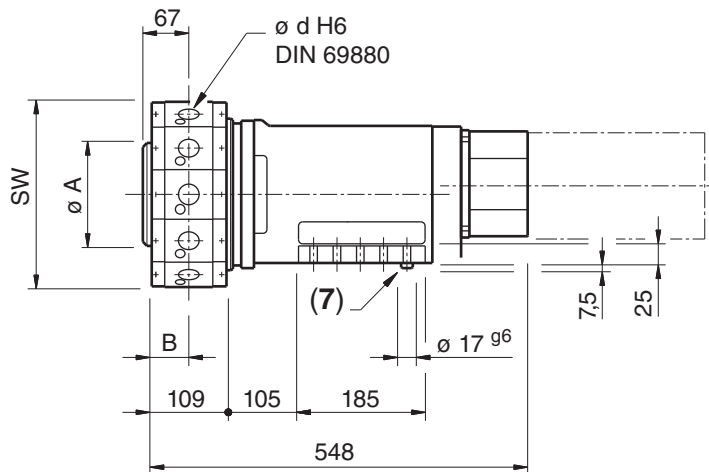

LEFT VERSION: Overall dimensions are mirror-image

- 1) Inlet coolant positions.
- 2) Hydraulic connections.
- 3) Centralized lubrication inlet.
- 4) Safety valve (drain).
- 5) Pressurizing air inlet.
- 6) Electrical connection.

Important: the connection cable must be provided with fittings and gaskets in order to avoid penetration of water into the turret.

- 7) Reference pin.
- 8) For overall dimensions of the "Compact" version, ask for relevant drawing.

Disc type	ød	SW	øA	B
12 pos.	30	370	170	54
16 pos.	25	300	220	46
16 pos.	30	340	240	54

SM-BA 20* / series 30

OVERALL DIMENSIONS

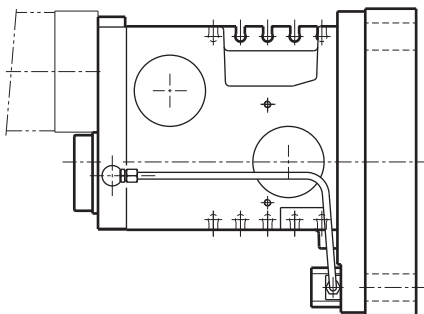
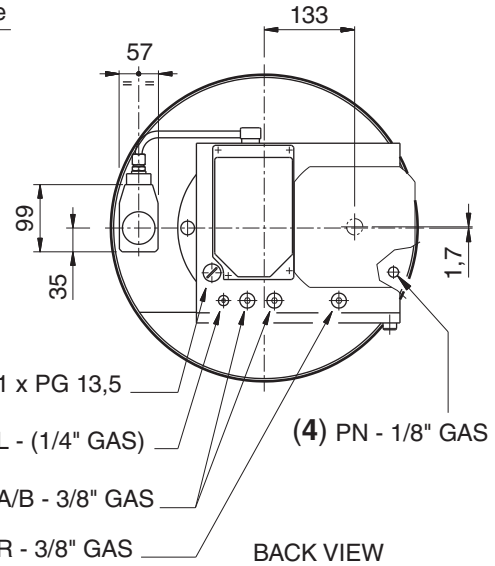
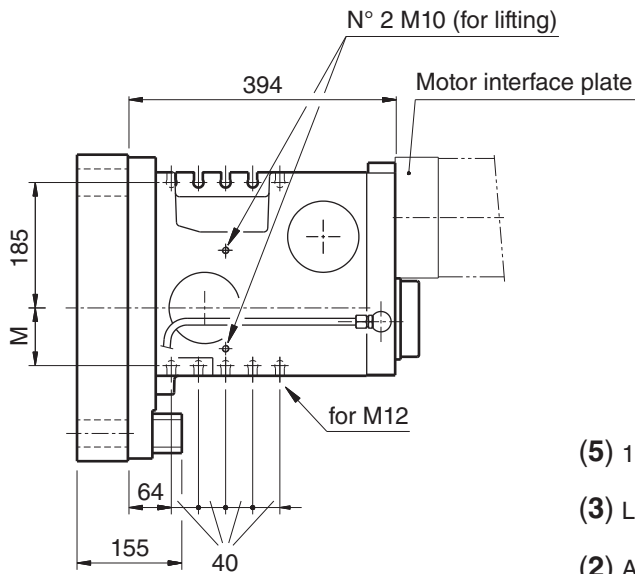
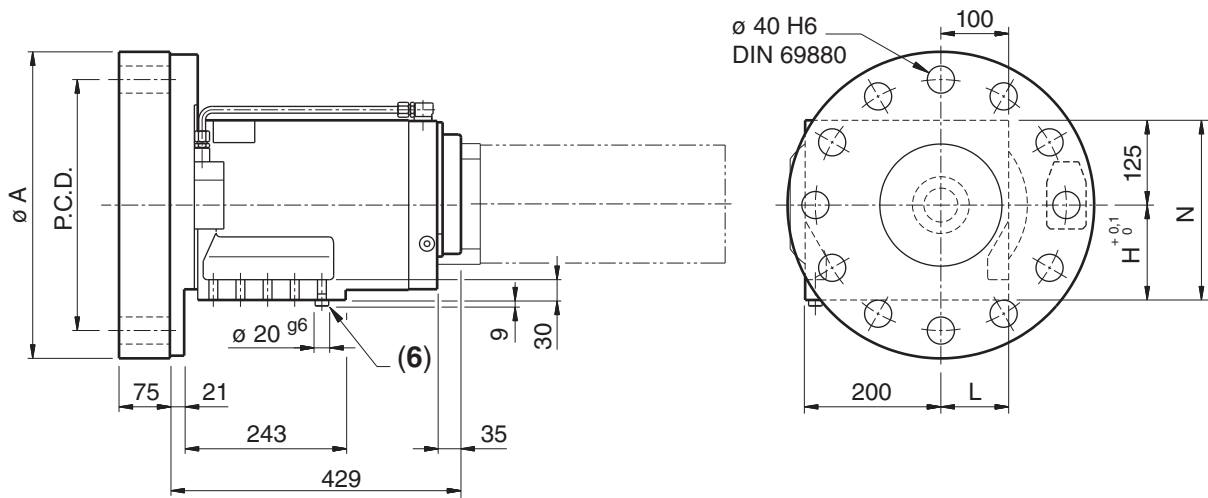

LEFT VERSION: overall dimensions are mirror-image

- 1) Inlet coolant positions.
- 2) Hydraulic connections.
- 3) Safety valve (drain).
- 4) Pressurizing air inlet.
- 5) Electrical connection.

Important: the connection cable must be provided with fittings and gaskets in order to avoid penetration of water into the turret.

- 6) Reference pin.

	P.C.D.	øA
Tool disc	340	420
	370	452

	H	L	M
SM-BA 20C	125	110	95
SM-BA 20F	140	100	85

SM-BR 20 / series 30

OVERALL DIMENSIONS

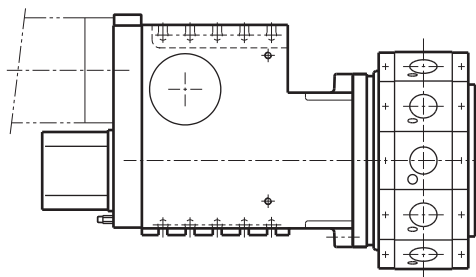
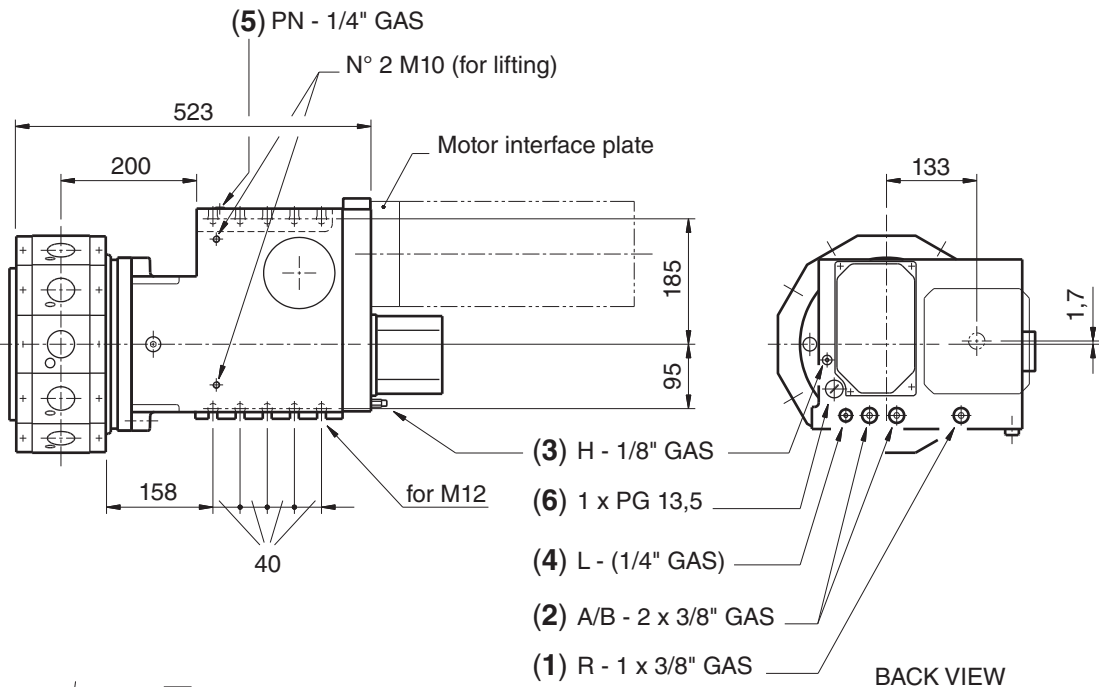
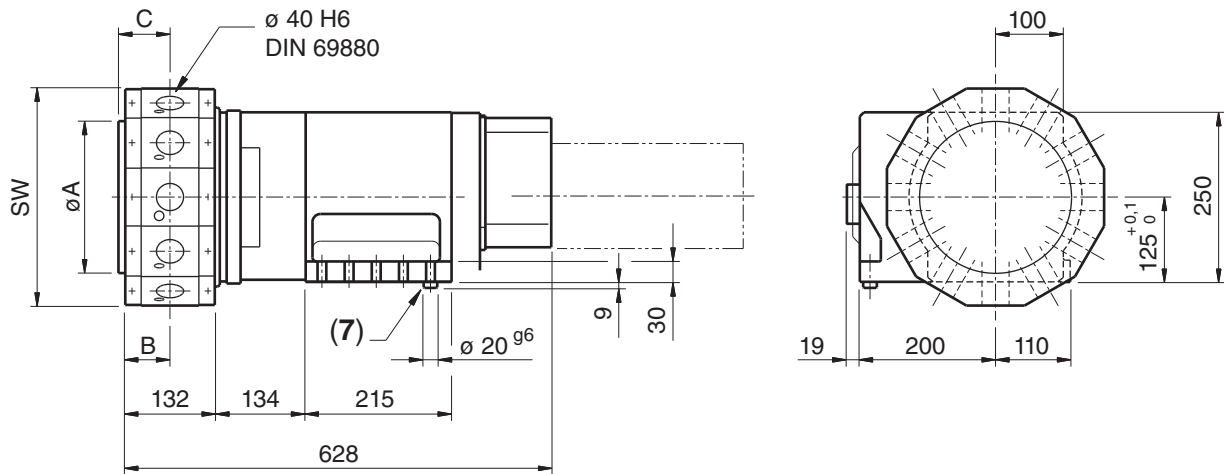

LEFT VERSION: overall dimensions are mirror-image

- 1) Inlet coolant positions.
- 2) Hydraulic connections.
- 3) Centralized lubrication inlet.
- 4) Safety valve (drain).
- 5) Pressurizing air inlet.
- 6) Electrical connection.

Important: the connection cable must be provided with fittings and gaskets in order to avoid penetration of water into the turret.

- 7) Reference pin.
- 8) For overall dimensions of the "Compact" version, ask for relevant drawing.

Disc type	ød	SW	øA	B	C
12 pos.	40	320	—	66	—
16 pos.	30	340	250	54	66
12 pos.	40	360	—	66	—
12 pos.	40	380	—	66	—

SM-BA 25 / series 30

OVERALL DIMENSIONS

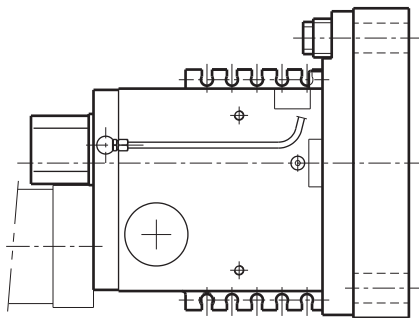
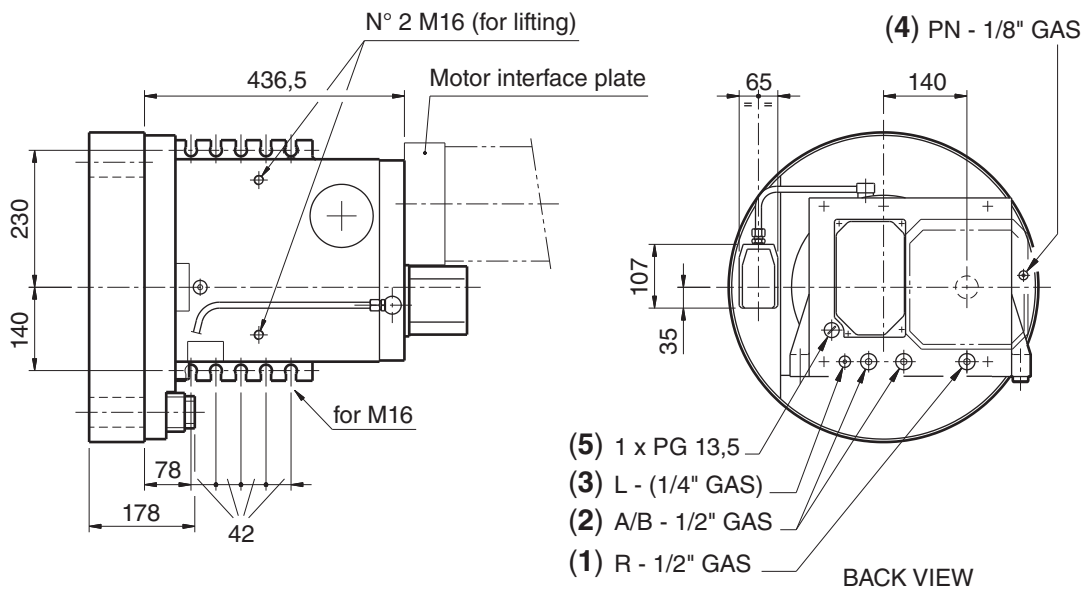
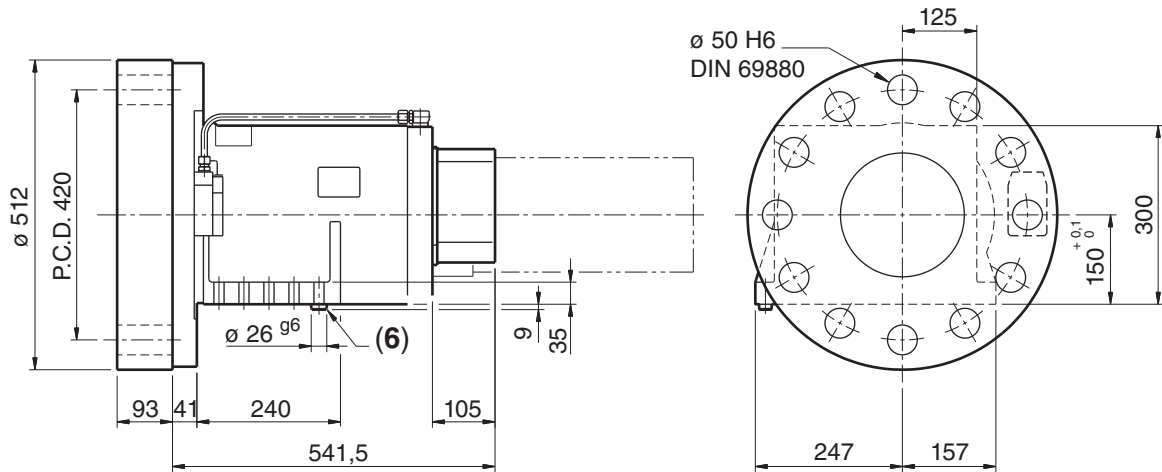

LEFT VERSION: overall dimensions are mirror-image

- 1) Inlet coolant positions.
- 2) Hydraulic connections.
- 3) Safety valve (drain).
- 4) Pressurizing air inlet.
- 5) Electrical connection.

Important: the connection cable must be provided with fittings and gaskets in order to avoid penetration of water into the turret.

- 6) Reference pin.

SM-BR 25 / series 30

OVERALL DIMENSIONS

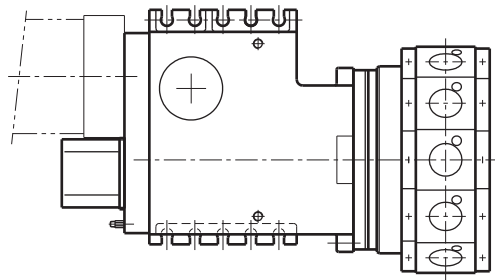
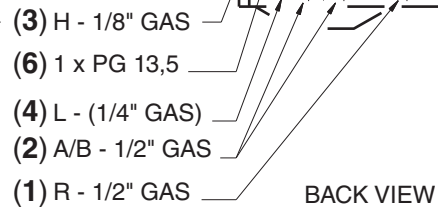
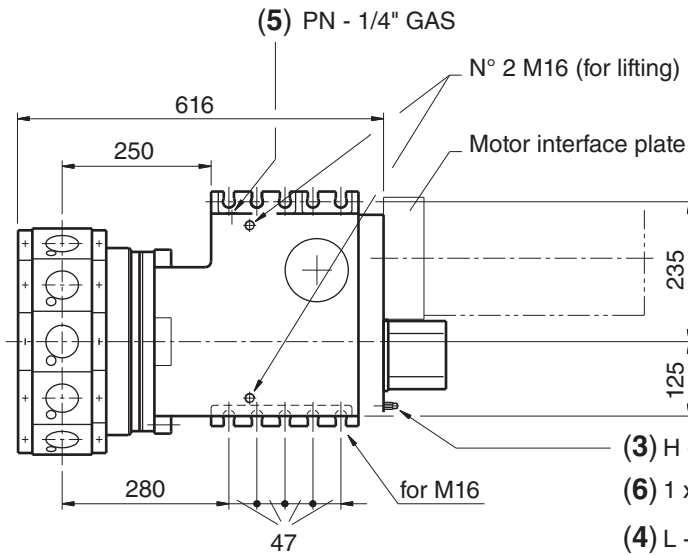
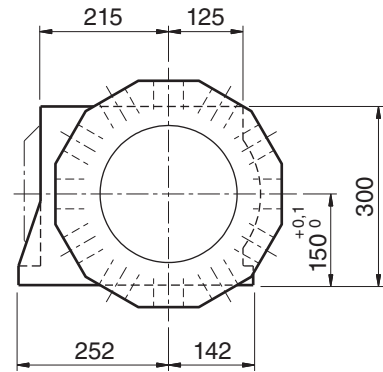
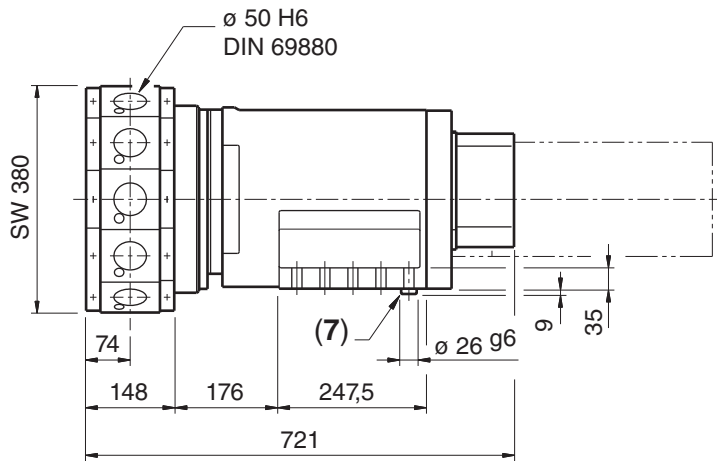

LEFT VERSION: Overall dimensions are mirror-image

- 1) Inlet coolant positions.
- 2) Hydraulic connections.
- 3) Centralized lubrication inlet.
- 4) Safety valve (drain).
- 5) Pressurizing air inlet.
- 6) Electrical connection.

Important: the connection cable must be provided with fittings and gaskets in order to avoid penetration of water into the turret.

- 7) Reference pin.
- 8) For overall dimensions of the "Compact" version, ask for relevant drawing.

SM-B * / series 30 HYDRAULIC DIAGRAM

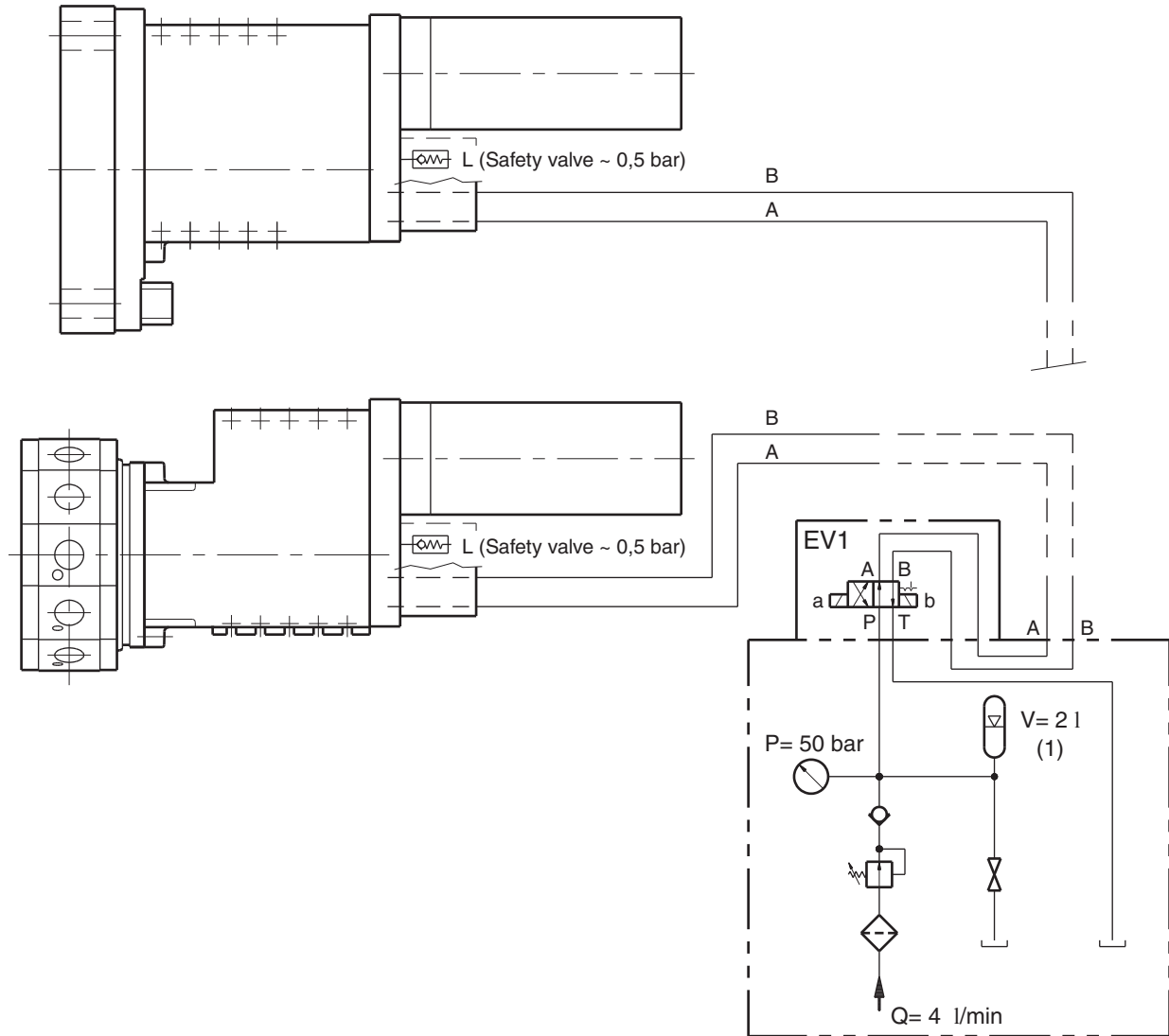

HYDRAULIC POWER PACK (Example)

Supply:

- Working pressure 50 ^{+ 5%} -20% bar
- Filtering 20 μm
- Oil viscosity 32 ÷ 46 mm²/s
- Recommended oil temperature ... 35 ÷ 55 °C

Functions	EV1	
	sol. a	sol. b
Clamping turret	-	+
Unclamping turret	+	-

DN recommended nominal diameter for hydraulic line					
Size	SM-B(*)	12	16	20	25
Length	≤ 6 m	6	8	10	12
	> 6 m	8	10	12	15

Size	SM-B(*)	12	16	20	25
Required oil volume [cm ³]	Clamping	20	27,5	53	61
	Unclamping	5	9,5	23	25
Needed istant flow [l/min]		9	12	18	18
	for	T _b =0,14s	T _b =0,14s	T _b =0,18s	T _b =0,22s

(1) The accumulator's volume is according to the real pump flow rate.

SM-B * / series 30

WIRING DIAGRAM

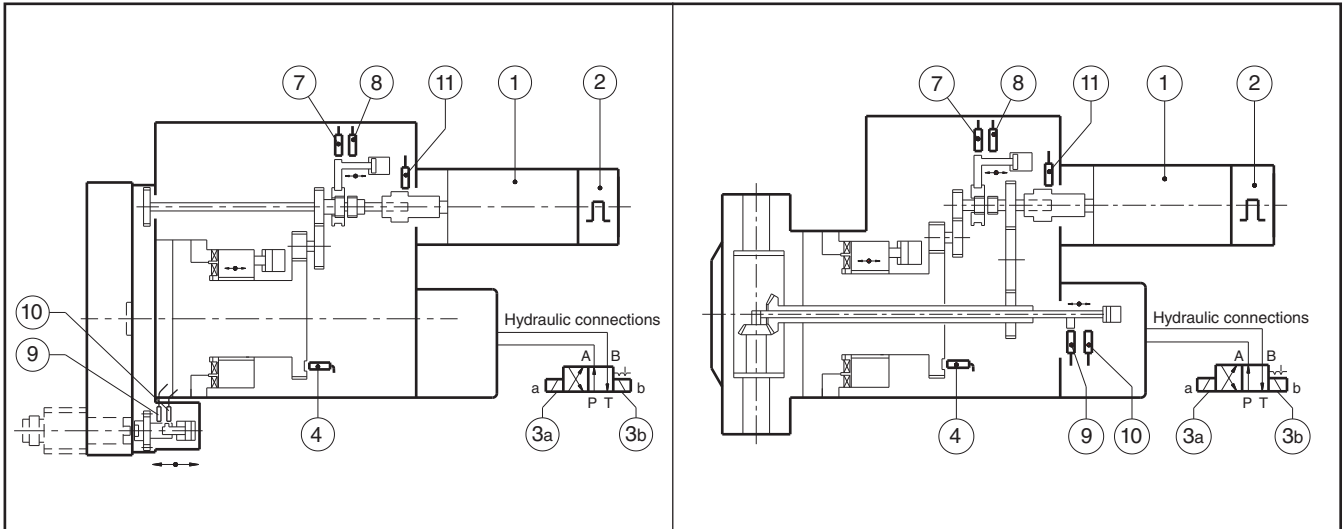

REF.	COMPONENT	CHARACTERISTICS	WIRING NUMBER		SIGNALS
			SYMBOLS	COLOUR	
①	MOTOR (1)	See data sheet of selected motor			
②	INCREMENTAL PULSE CODER				
③a	VALVE	Sol a			+ COMMON
③b		Sol b			+ COMMON
④	TURRET ZERO POINT SWITCH	24V D.C. ± 10% 200 mA (load) OUTPUT-PNP-NO		10 BROWN 11 BLACK 12 BLUE	+ V D.C. OUTPUT 0 V D.C.
⑦	TURRET ROTATION NOT ENGAGED SWITCH			10 BROWN 15 BLACK 12 BLUE	+ V D.C. OUTPUT 0 V D.C.
⑧	TURRET ROTATION ENGAGED SWITCH			10 BROWN 16 BLACK 12 BLUE	+ V D.C. OUTPUT 0 V D.C.
⑨	TOOL ENGAGED SWITCH			10 BROWN 17 BLACK 12 BLUE	+ V D.C. OUTPUT 0 V D.C.
⑩	TOOL NOT ENGAGED SWITCH			10 BROWN 18 BLACK 12 BLUE	+ V D.C. OUTPUT 0 V D.C.
				GREEN / YELLOW	PE

OPTIONAL

⑪	OVERLOAD CLUTCH SWITCH	24V D.C. ± 10% 200 mA (load) OUTPUT-PNP-NO		10 BROWN 19 BLACK 12 BLUE	+ V D.C. OUTPUT 0 V D.C.
---	------------------------	--	--	---------------------------------	-----------------------------

1) Use only servomotors with "orientation function" by CNC.

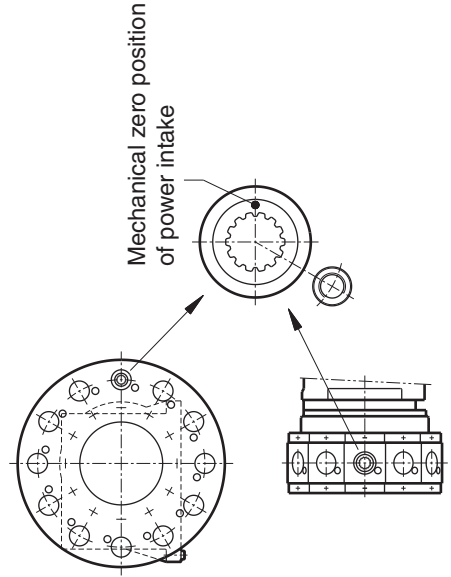
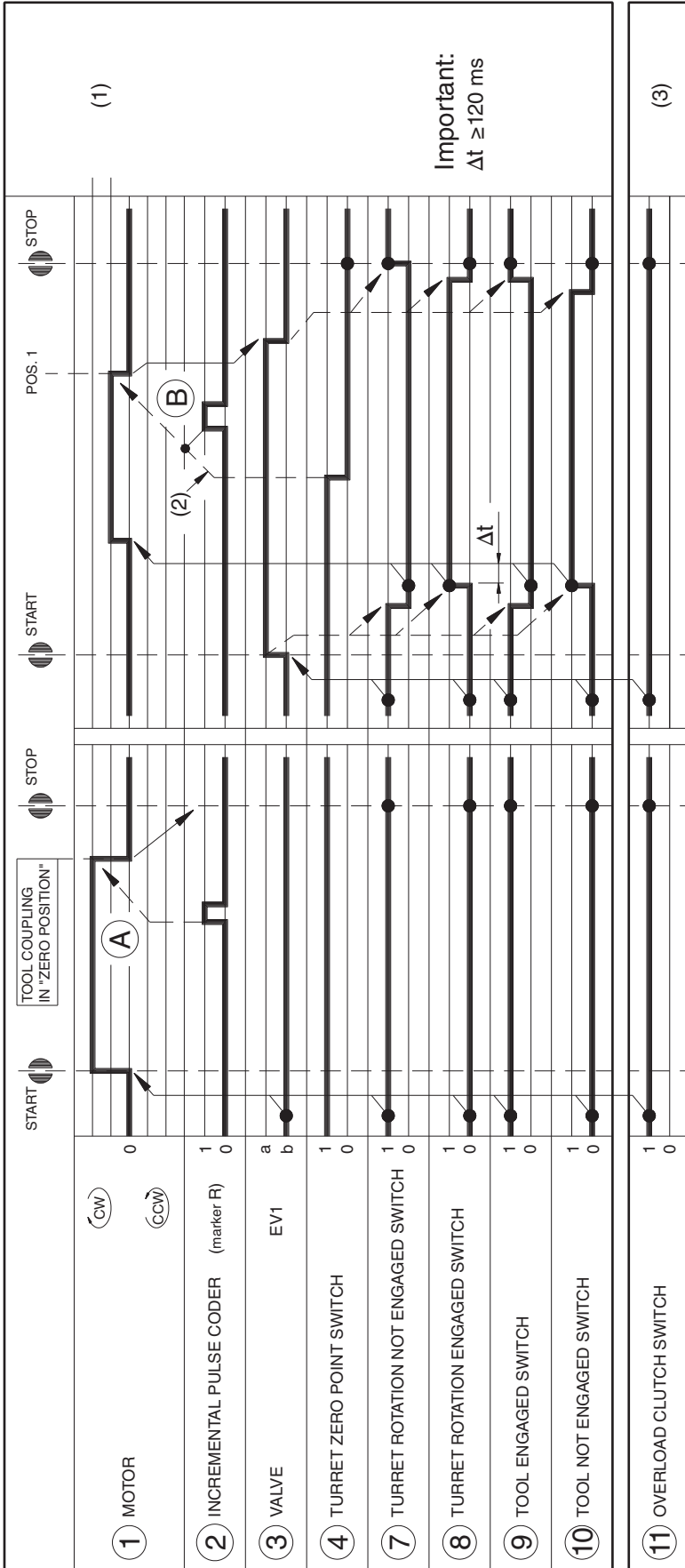

A The distance between coder marker and driven tools zero position must be set.

B The distance between coder marker and turret zero position must be set.

NOTES:

- (1) The motor speeds for turret zero setting and tool zero setting must be according to CN/driver specs.
- (2) The zero position stop depends on the "orientation function" of CN.
- (3) The signal of the overload clutch switch (11) is high at normal working conditions.
The absence of this signal means an emergency condition: in this case the motor must be stopped immediately.

SM-B * / series 30 PRESSURIZING AIR SYSTEM (A1)

This turret has been preset with a pressurizing function in order to prevent external agent contamination on side tool disc causing the rotary seal damage. Mainly, it is suitable for machining on materials that create dust or string-form chips.

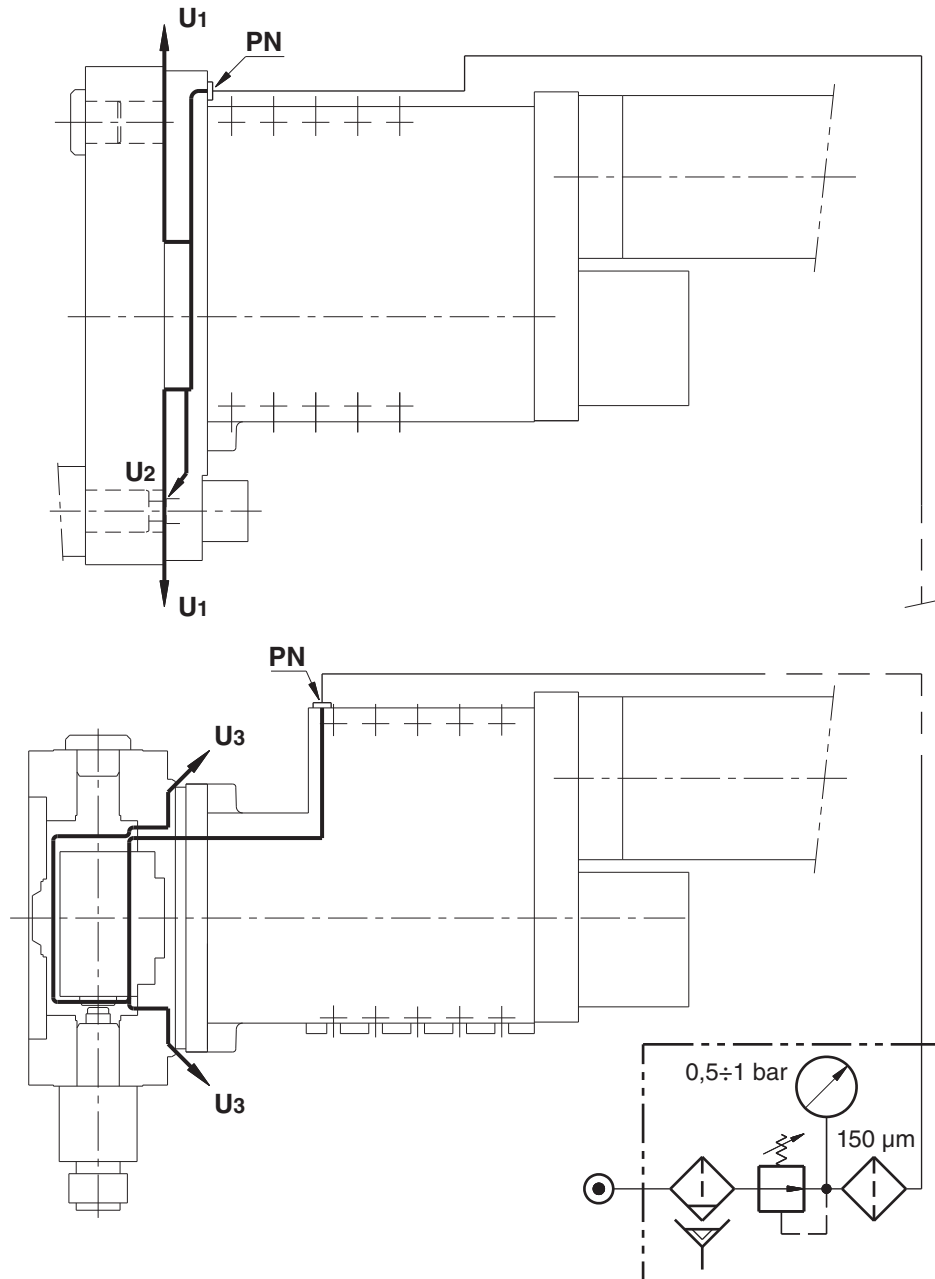

PN • PRESSURIZING AIR INLET :

- Air supply: • Max pressure 0,5±1,0 bar.
- Flow ~ 50 l/min.
- Filtering ≤ 150 µm.

U • PRESSURIZING AIR OUTLET :

- U₁ • Between disc and driven tool system
- U₂ • In seal area
- U₃ • Between disc and coolant flange

SM-BR * / series 30 CENTRALIZED LUBRICATION SYSTEM (L1)

This turret has been preset with a lubrication function in order to prevent that central module's wearing is increased due to heavy driven tool duty cycle. This function must be connected to the central lubrication system of the machine.

ATTENTION: This function is supplied on the turret radial version only because the possible lubricant absence is very critical for the turret central module.

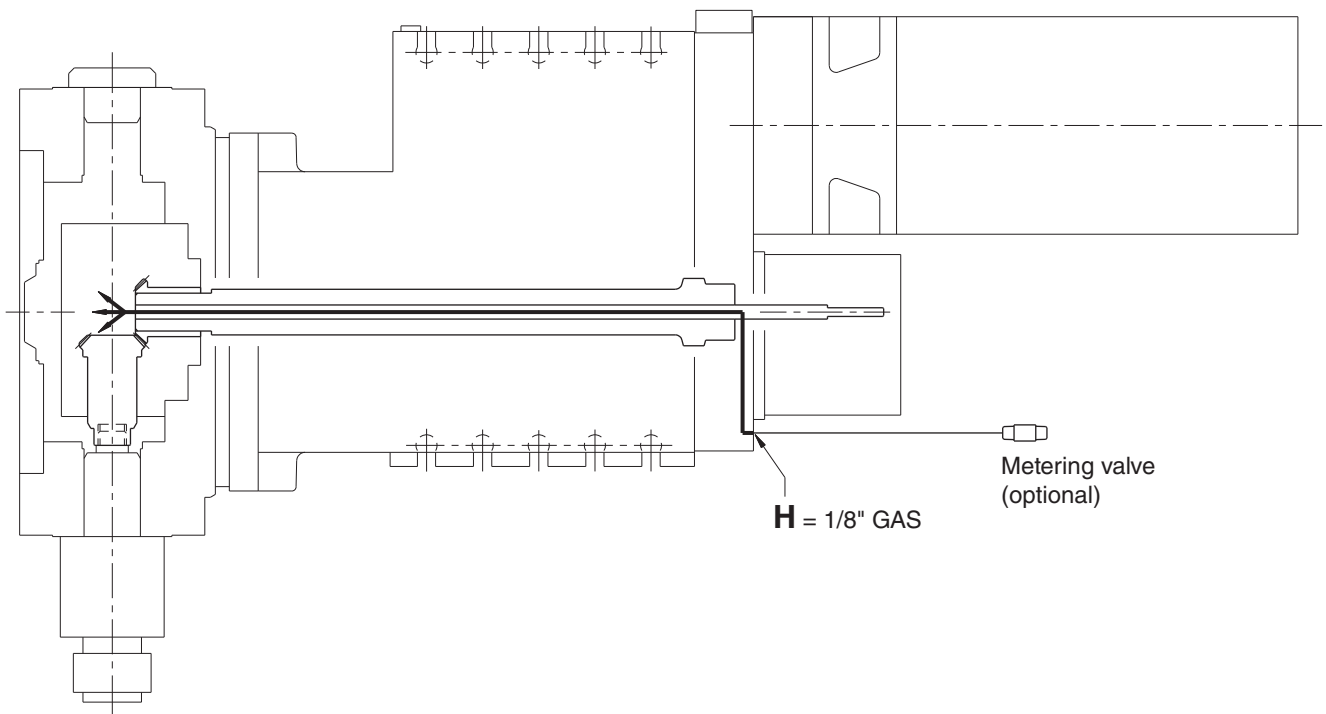

H • LUBRICATION INLET:

- Lubrication supply:
- Required oil volume : 0,06 cm³/ cycle
 - Lubrication frequency : 6 cycle / h
Note: Depending on driven tool duty cycle.
 - Type of lubricant : Oil with viscosity \leq 750 cSt (40°) or fluid grease.

WARNING: If oil contamination inside the working area is not allowed, please contact our Technical Dept.

SM-B * / series 30

ROTATING TOOLHOLDERS SPECS

- Coupling according to DIN 5480 and zero detent system.

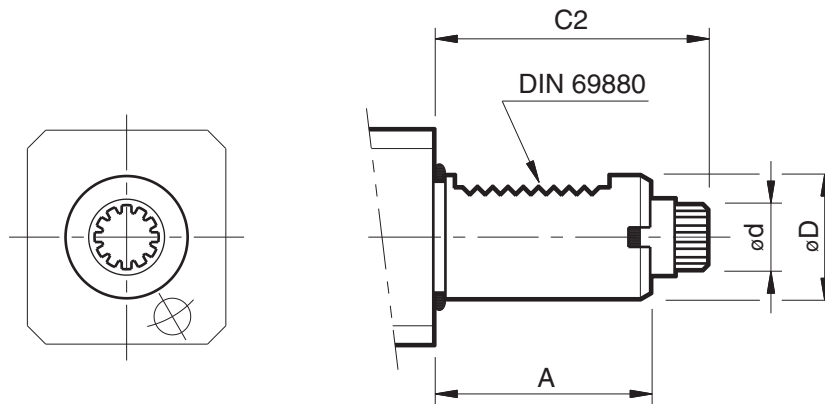

	$\varnothing D$	A	C 2	L	Z	$\varnothing d$
SM-B* 12	25 ^{h6}	48	57	62,5	50	DIN 5480 W14 x 0,8 x 30 x 16
SM-B* 16	30 ^{h6}	55	67	69,5	57	DIN 5480 W16 x 0,8 x 30 x 18
SM-B* 20	40 ^{h6}	63	75	77,5	65	DIN 5480 W20 x 0,8 x 30 x 24
SM-B* 25	50 ^{h6}	78	93	95	82,5	DIN 5480 W24 x 1,25 x 30 x 18

[mm]

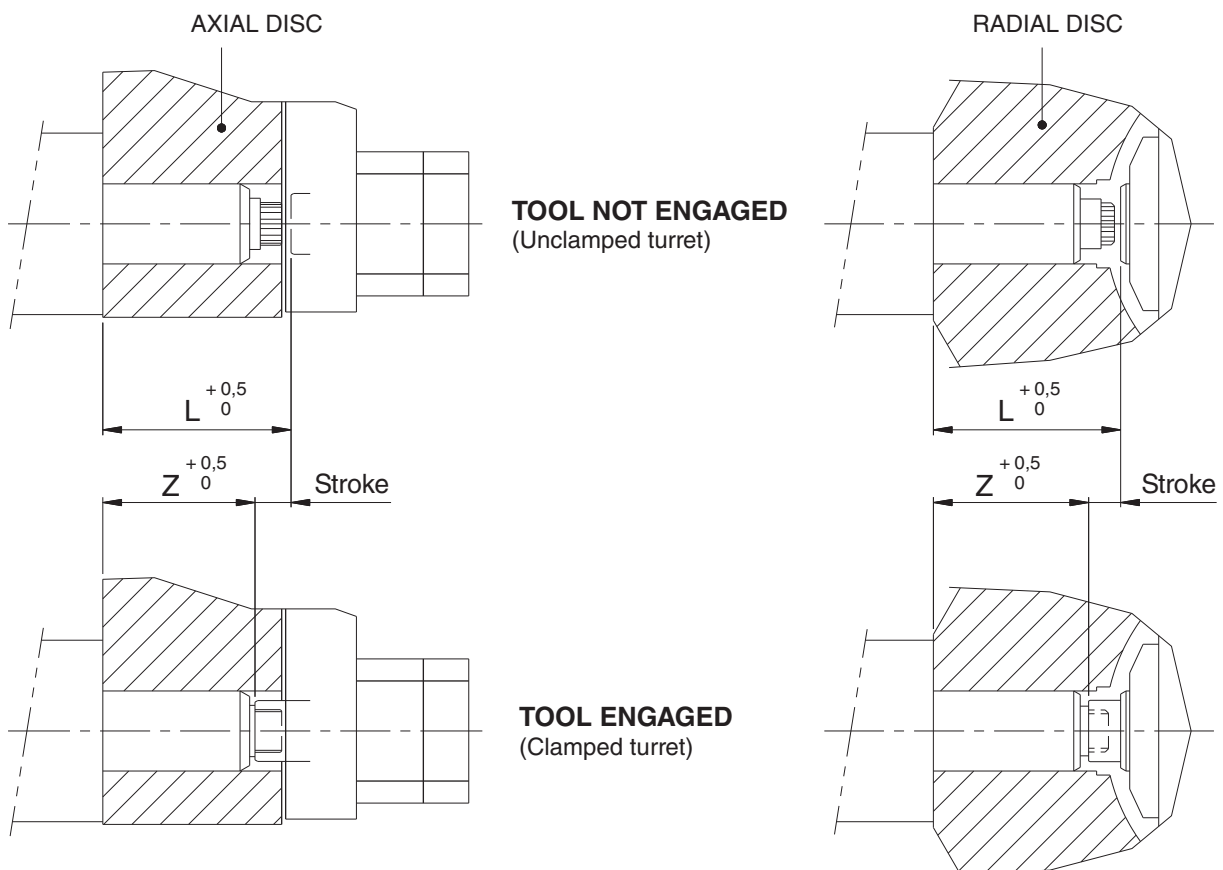

SM-B * / series 30 ROTATING TOOLHOLDERS SPECS

- This plate is supplied with the SM-B* device, and it must be fitted on the machine so as to be very clearly seen.

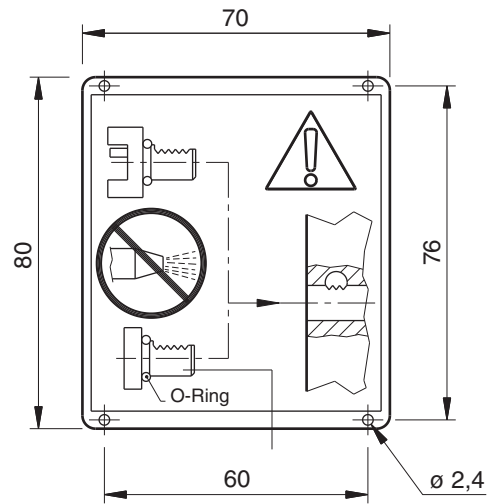

Note: Housing not engaged with toolholders must be properly plugged. (DIN 69880 Shape Z2).

- Angular adjusting pins on disc (for radial rotating units)

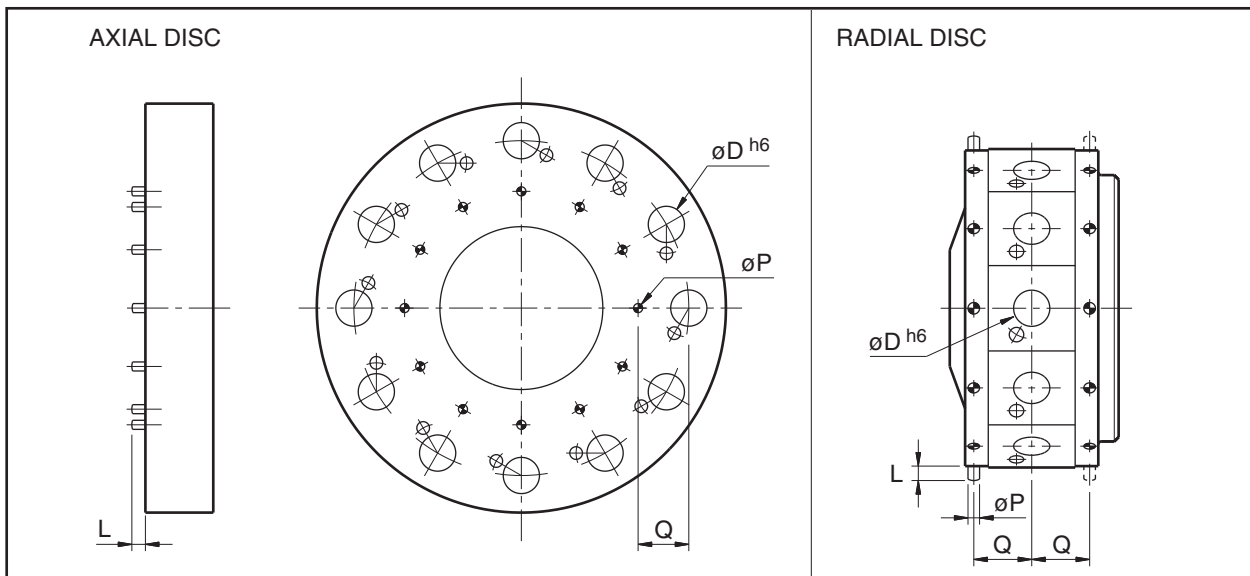

	$\varnothing D$	$\varnothing P$	Q	L
SM-B* 12	25	8	40	10
SM-B* 16	30	8	48	10
SM-B* 20	40	10	56	15
SM-B* 25	50	10	64	15

[mm]

SM-B * / series 30 SUPPLY COMPOSITION

SM-BA *

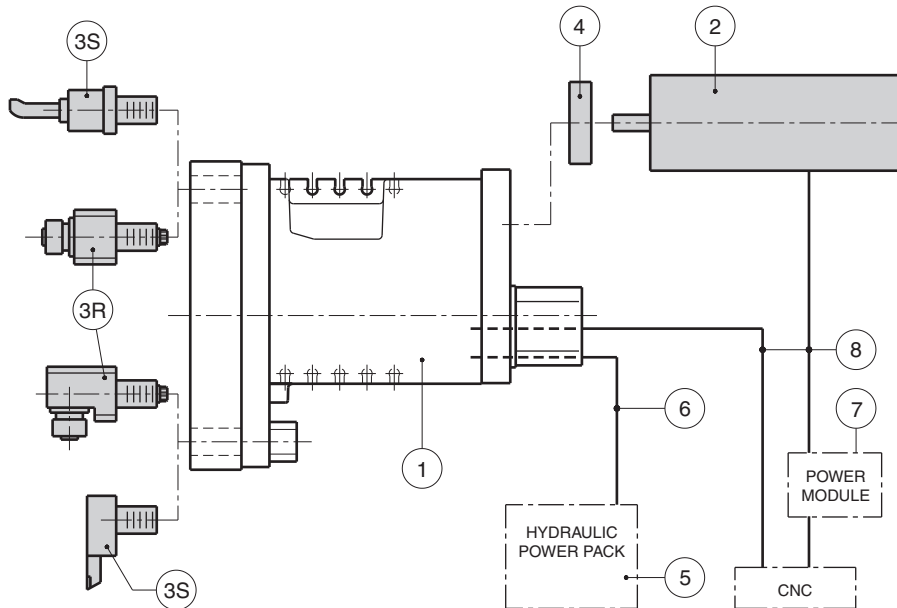

SM-BR *

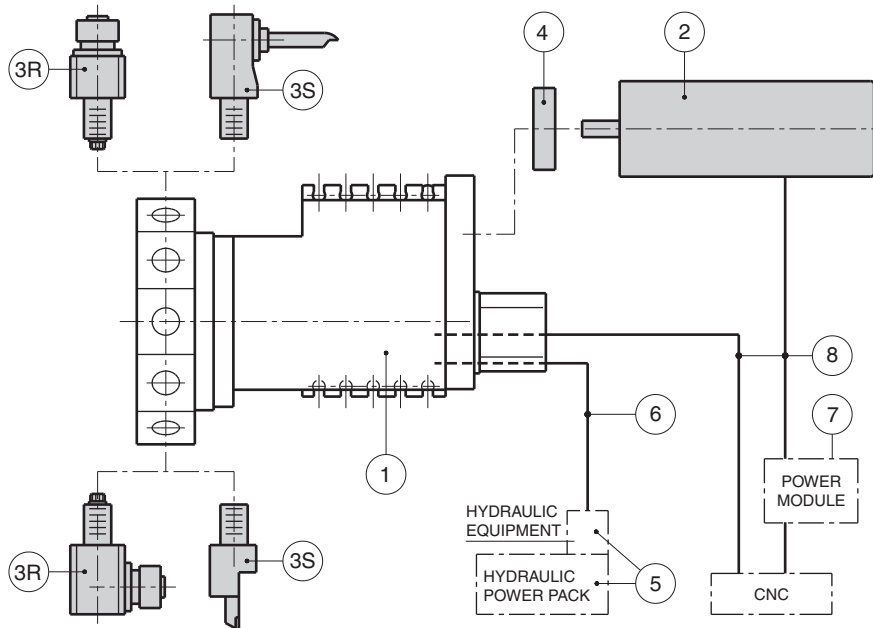

(1) Tool turret with tooldisc.

Optionals:

- (2) Servomotor.
- (3) Rotating and Static toolholders.
- (4) Overload clutch at the motor.

Excluded:

- (5) Hydraulic power pack.
- (6) Hydraulic connections.
- (7) Power module.
- (8) Electrical connections

SM-B* - * * - * - * - * - * / 3* -A1- (*)



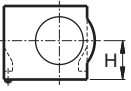

DRIVEN TOOLS	
without	—
with	A

SIZES	
SM-BA 12	12
SM-BA 16	16
SM-BA 20	20
SM-BA 25	25

HOUSING HEIGHT					
Size	12	16	20	25	
	90	100	125	150	C
	—	—	140	—	F

TOOL DISC SW DIMENSION and ⁽¹⁾ TOOL HOLDER SEATS DIN 69880		
270	25	SM-BA 12
340	30	SM-BA 16
370	40	SM-BA 20
420	50	SM-BA 25

POSITIONS	
12 Pos.	12

VERSION ⁽²⁾			
		Tool disc	Turret
D1		Right	Right
D2		Left	
S1		Right	Left
S2		Left	

(1) Other size on request.
(2) See sheet C2-6.

SM-BR * / series 30

IDENTIFICATION CODE

SM-B* - ** - * - * - * - * / 3* -A1L1- (*)

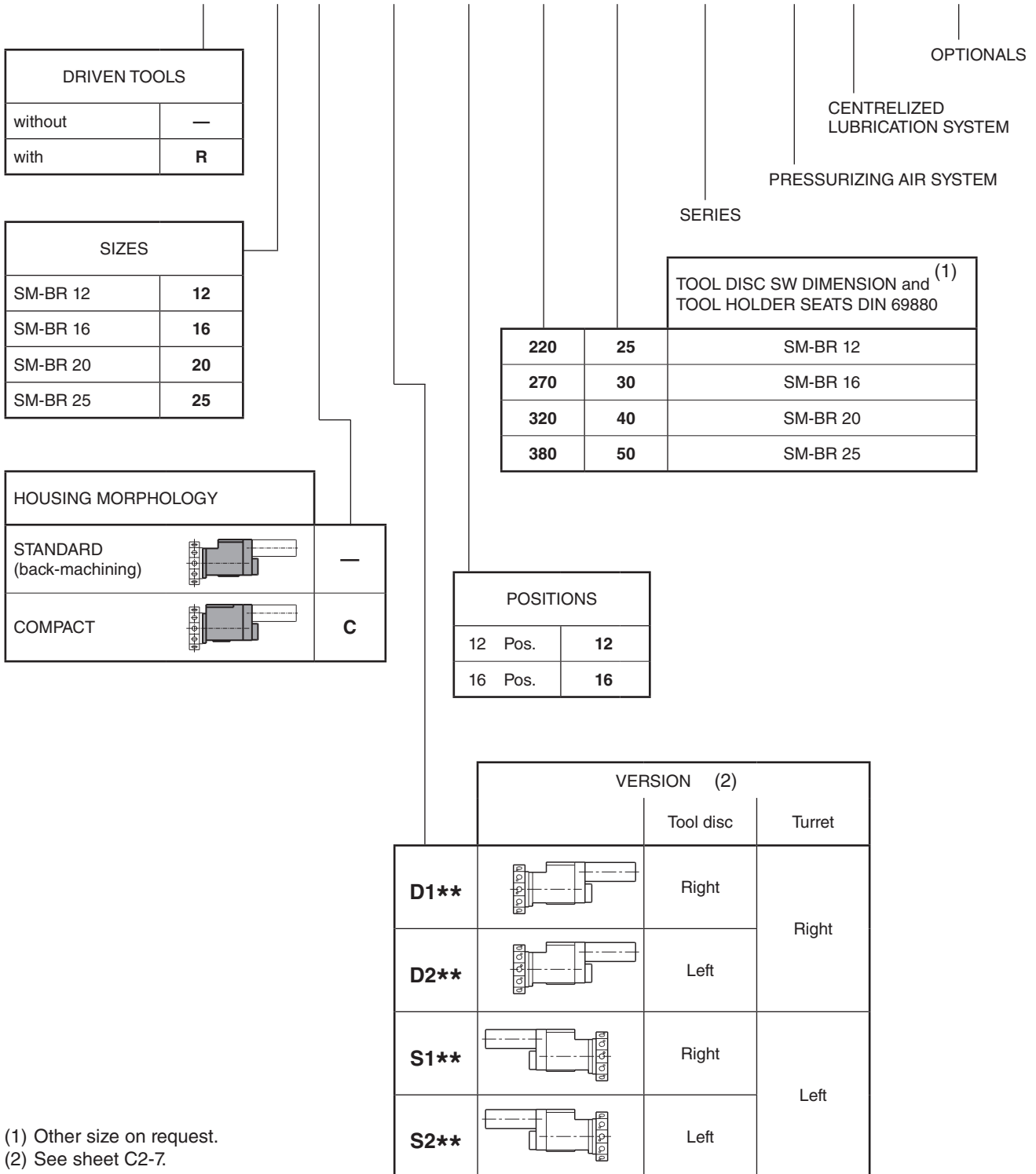

(1) Other size on request.
(2) See sheet C2-7.

DIPLOMATIC AUTOMATION S.r.l.
20025 LEGNANO (MI) - ITALY
P.LE BOZZI, 1
PHONE 0331/472111
FAX 0331/455161



DIPLOMATIC
AUTOMATION

e-mail: info@diplomatic.it

come visit Diplomatic homepage:
www.diplomaticautomation.com