

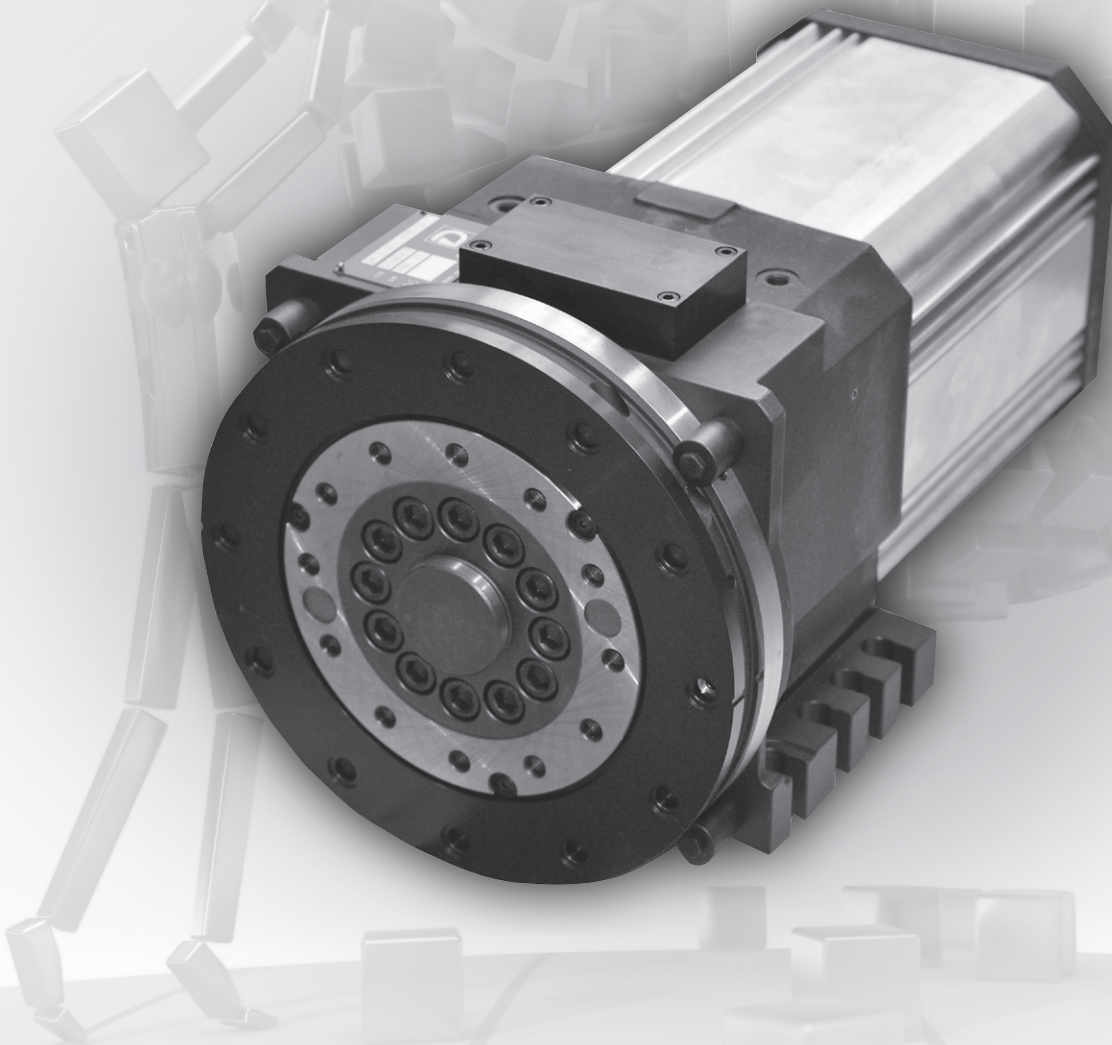

DIPLOMATIC
AUTOMATION



DM-* series 10

DIRECT DRIVE SERVOMOTOR TURRETS

(PATENTED)



TECHNICAL INFORMATION

I.T. 6458

GB ISSUED **05-09**

The data given in the I.T. are subject to technical modifications without notice.

MAIN FEATURES :

- Original Diplomatic solution for dedicated direct drive.
- No backlash, no wearing, noiseless.
- Same performances as SM turrets.
- High loading capacity with the minimum working pressure of 35 bar.
- Absolute tool position signal: no zero cycle required.
- Standard range of coolant pressure up to 30 bar.
- Full mechanical interchangeability with BSV-N/SM turrets.

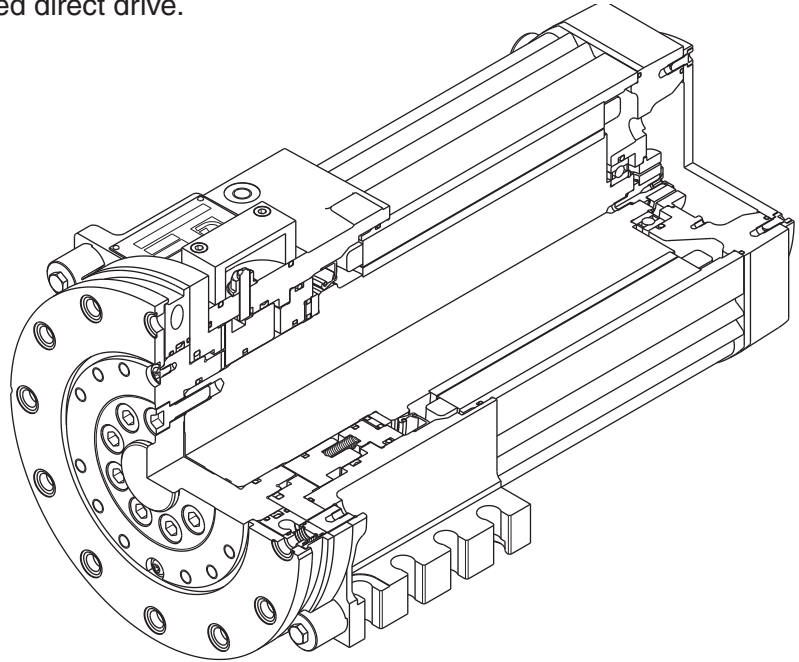

Easier maintenance and higher reliability :

- Less number of components.
- Quick electrical connections.
- Lower critical level of dynamic crash.



TMC* new control unit

- Dedicated lean design: only the basic functions are managed.
- CNC logic interface similar to current DDC4.
- Alarm code displayed on the unit.
- Extended diagnostic information can be directly available on the machine control panel.
- Availability of a diagnostic software.

Technical data

Size			DM-12		DM-16		DM-20		DM-25	
Tool stations	N°		8÷12		8÷12		8÷12		8÷12	
Inertia of transportable masses (1)	Kgm ²		0,8	1,2	1,2	2,2	3	5	5	9
Positioning times: (2)										
one step index time	30°	s	0,17	0,21	0,18	0,23	0,24	0,31	0,31	0,40
	45°	s	0,21	0,25	0,22	0,29	0,30	0,38	0,38	0,48
	180°	s	0,51	0,56	0,52	0,60	0,66	0,78	0,78	0,98
step-less rotation time	30°	s	0,067	0,067	0,067	0,067	0,08	0,08	0,08	0,08
	45°	s	0,10	0,10	0,10	0,10	0,12	0,12	0,12	0,12
(Tsb) Unclamping or (Tb) Clamping time (2)	hydraulic	s	0,14		0,14		0,18		0,22	
Indexing frequency $\alpha = 90^\circ$	Cycle/min		16	14	13	11	12	10	11	9
Working pressure	hydraulic	bar	40 ±5		40 ±5		40 ±5		40 ±5	
Electric supply - Inputs / Outputs			see electric diagram		see electric diagram		see electric diagram		see electric diagram	
Mass (without disc)	Kg		40		62		100		130	
Ambient temperature range			°C		5 ÷ 40		5 ÷ 40		5 ÷ 40	
Coolant supply :										
Standard : (3)										
• Costant flow		bar	7		7		7		7	
• Pressure cut-off during turret rotation		bar	30		30		30		30	
Protection degree (DIN 40050)			IP 65		IP 65		IP 65		IP 65	

(1) Larger inertia values can be applied with increased indexing times

(2) Conditions:

- Hydraulic supply properly sized.
- Without dead-times caused by machine CNC.

(3) Filtering ≤ 100 µm.

Accuracy

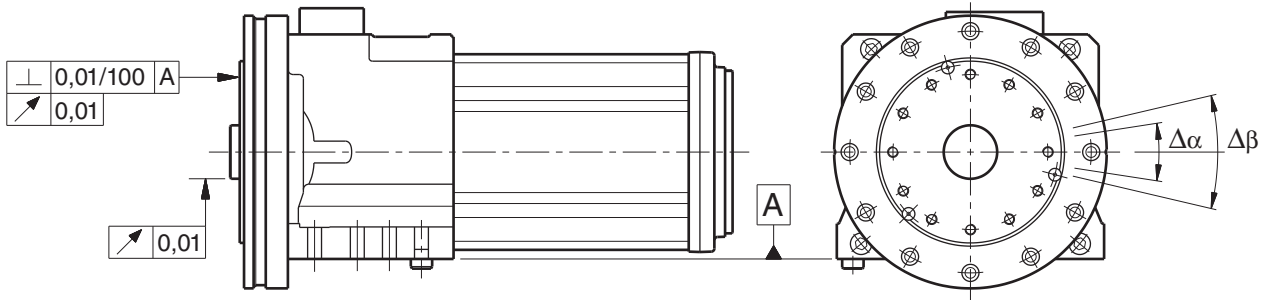

Repeatability accuracy $\Delta\alpha = \pm 1,6''$ (0,78 $\mu\text{m}/100 \text{ mm}$)

Indexing accuracy $\Delta\beta = \pm 4''$ (1,9 $\mu\text{m}/100 \text{ mm}$)

Loading capacity

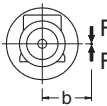
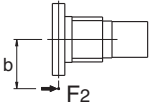
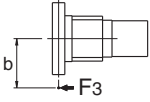
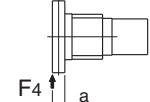
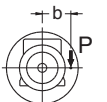
			DM-12	DM-16	DM-20	DM-25
	Max. tangential torque $F_1 \times b$	Nm	750	1.600	3.500	6.000
	Max. tilting torque to push $F_2 \times b$	Nm	900	1.900	5.200	10.000
	Max. tilting torque to lift $F_3 \times b$	Nm	500	1.500	3.000	4.500
	Max. radial tilting torque $F_4 \times a$	Nm	500	1.500	3.000	4.500
	Unbalancing torque $P \times b$	Nm	16	22	40	60

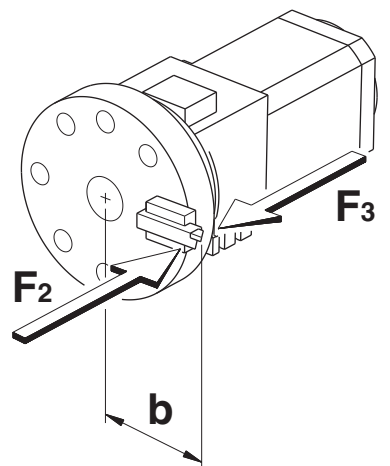
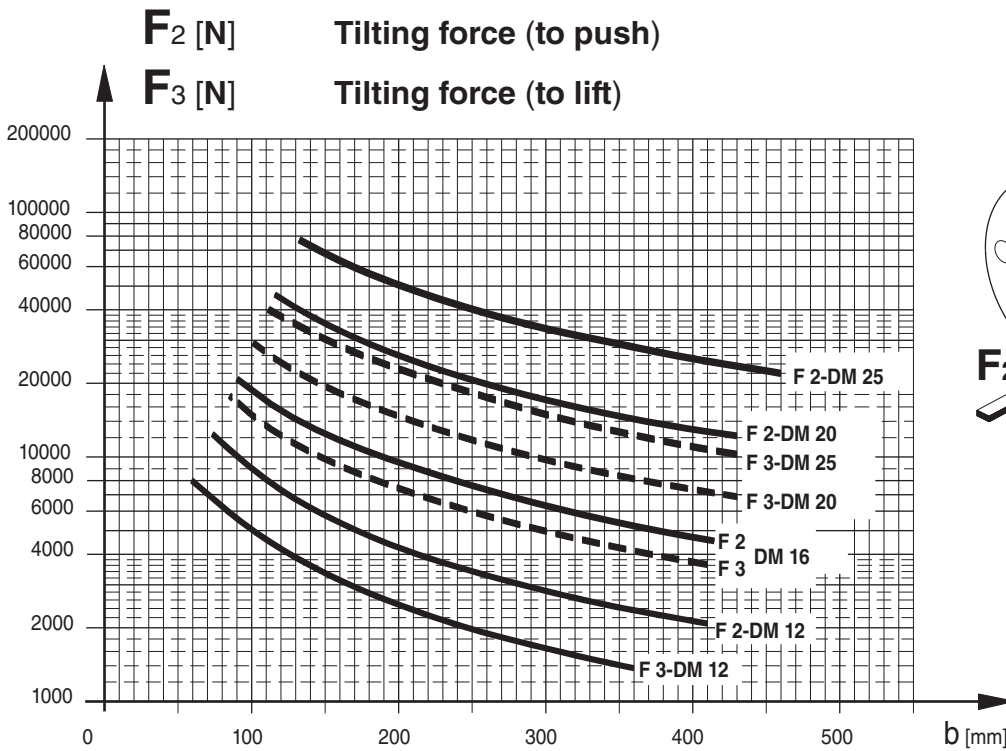
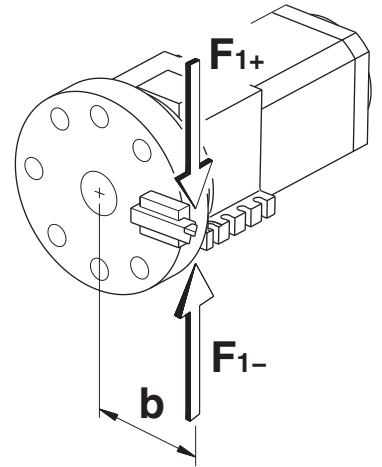
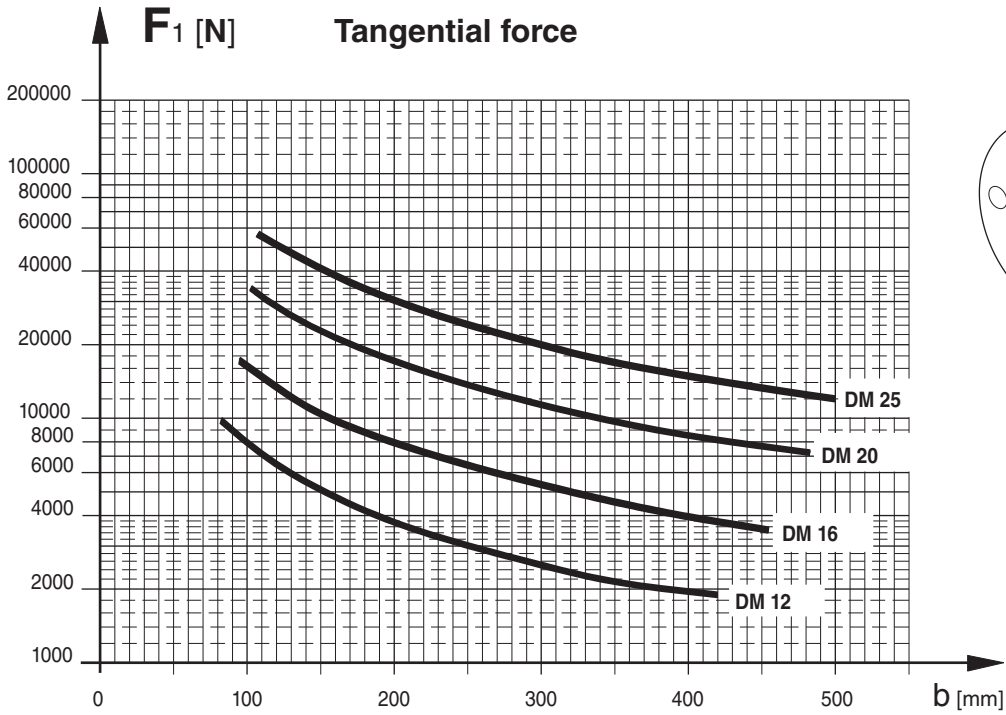

DM-12 / series 10

OVERALL DIMENSIONS

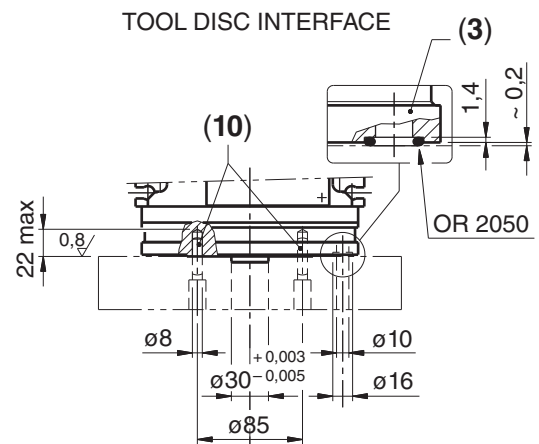
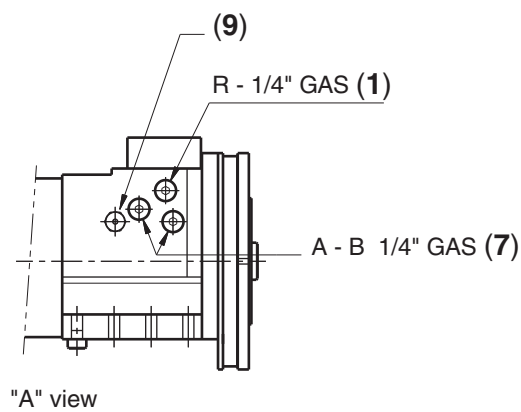
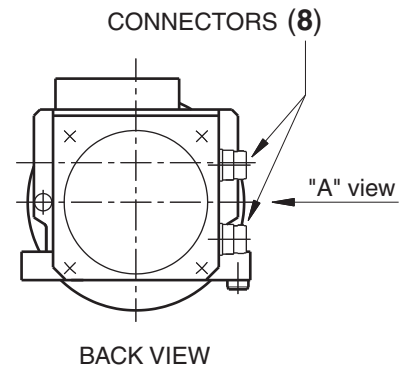
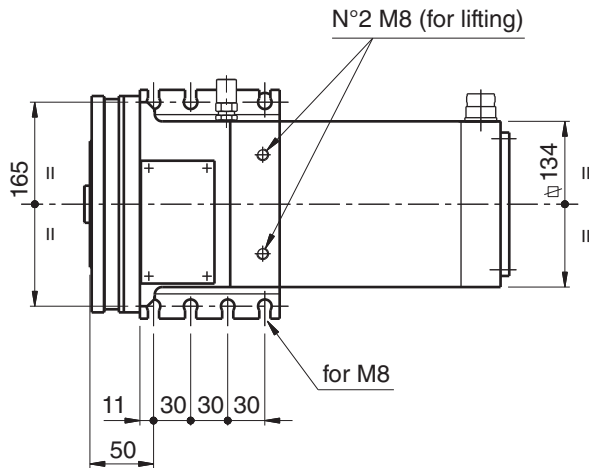
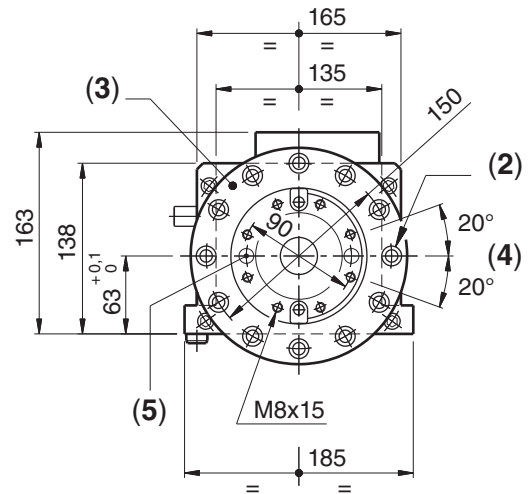
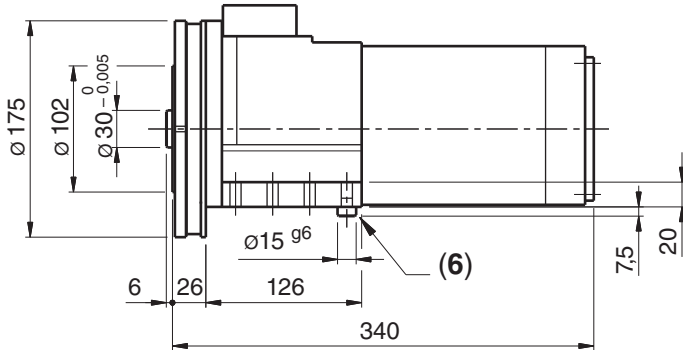

- 1) Inlet coolant position.
 - 2) Coolant outlet position.
 - 3) Adjustable coolant ring.
 - 4) Coolant outlet displacement range.
 - 5) Positions for boring the disc reference pins.
 - 6) Reference pin.
 - 7) Hydraulic connections.
 - 8) Electrical connectors.
 - 9) Safety valve (drain).
 - 10) Reference pins between tool disc and turret.
- Note:** Overall dimensions and fixing interchangeable with SM* turrets.

DM-16 / series 10 OVERALL DIMENSIONS

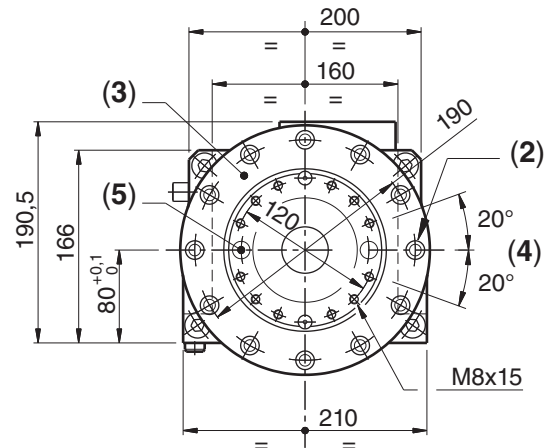
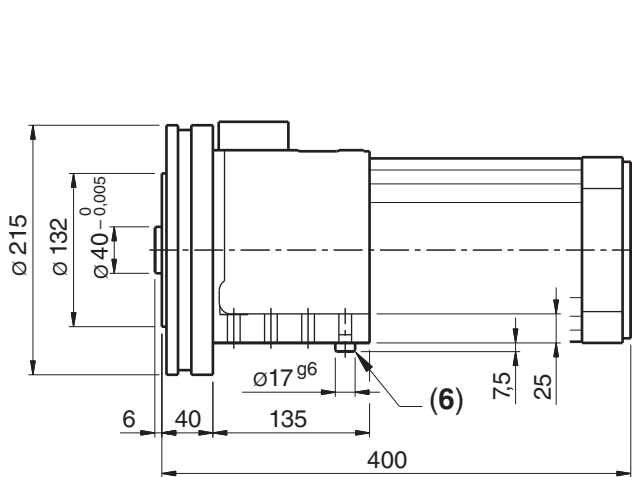

A1 - B1 1/4" GAS (7)
(Additional ports)

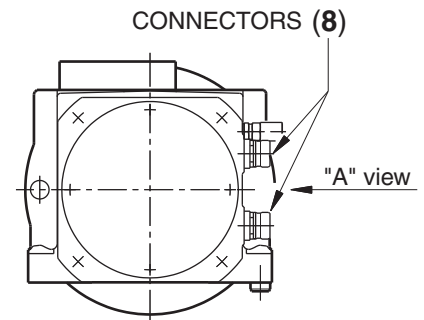
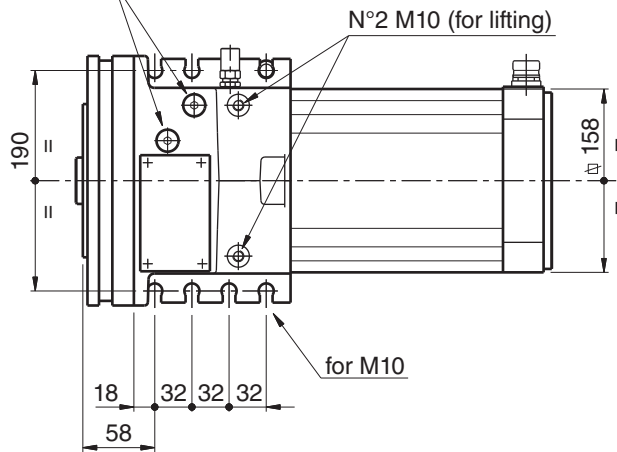

BACK VIEW

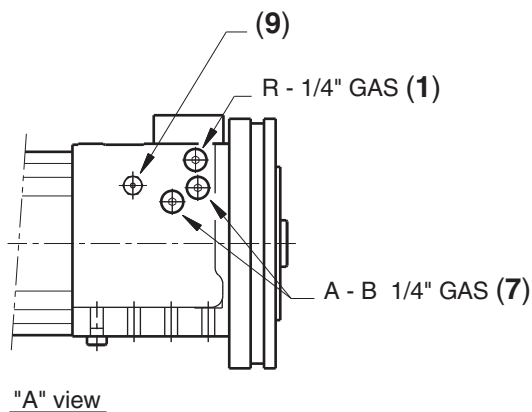

"A" view

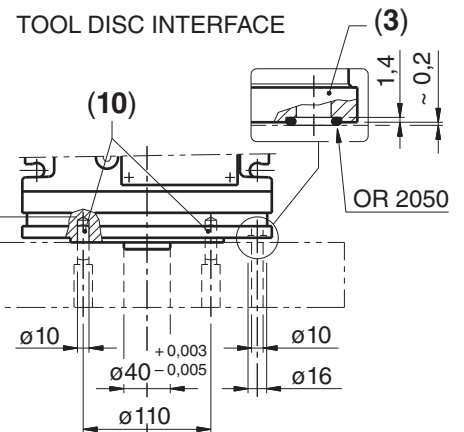

- 1) Inlet coolant position.
- 2) Coolant outlet position.
- 3) Adjustable coolant ring.
- 4) Coolant outlet displacement range.
- 5) Positions for boring the disc reference pins.
- 6) Reference pin.

- 7) Hydraulic connections.
- 8) Electrical connectors.
- 9) Safety valve (drain).
- 10) Reference pins between tool disc and turret.

Note: Overall dimensions and fixing interchangeable with SM* turrets.

DM-20 / series 10

OVERALL DIMENSIONS

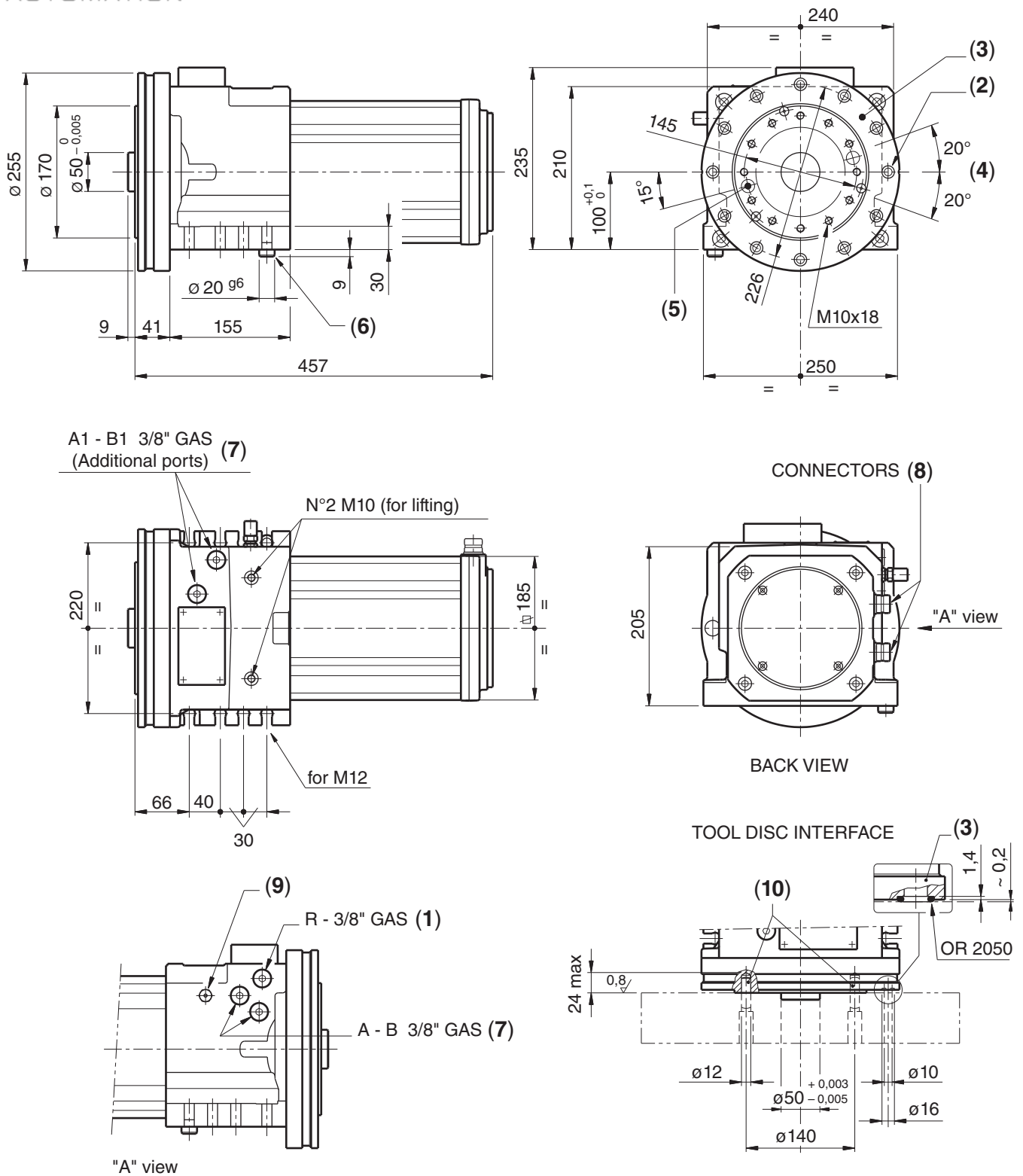

- 1) Inlet coolant position.
 - 2) Coolant outlet position.
 - 3) Adjustable coolant ring.
 - 4) Coolant outlet displacement range.
 - 5) Positions for boring the disc reference pins.
 - 6) Reference pin.
 - 7) Hydraulic connections.
 - 8) Electrical connectors.
 - 9) Safety valve (drain).
 - 10) Reference pins between tool disc and turret.
- Note:** Overall dimensions and fixing interchangeable with SM* turrets.

DM-25 / series 10

OVERALL DIMENSIONS

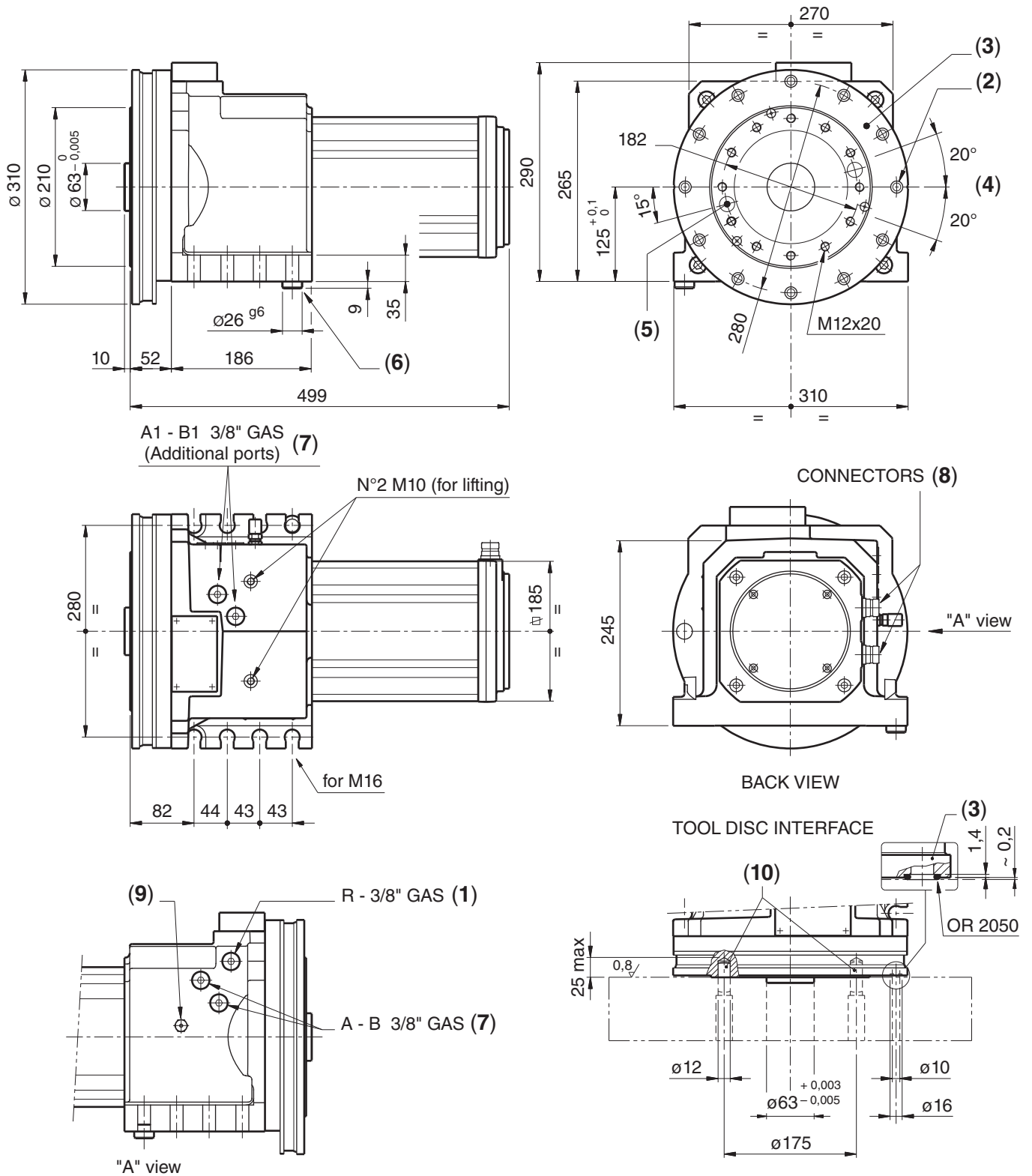

- 1) Inlet coolant position.
- 2) Coolant outlet position.
- 3) Adjustable coolant ring.
- 4) Coolant outlet displacement range.
- 5) Positions for boring the disc reference pins.
- 6) Reference pin.
- 7) Hydraulic connections.
- 8) Electrical connectors.
- 9) Safety valve (drain).
- 10) Reference pins between tool disc and turret.

Note: Overall dimensions and fixing interchangeable with SM* turrets.

LEFT VERSIONS (valid for all the turret sizes)

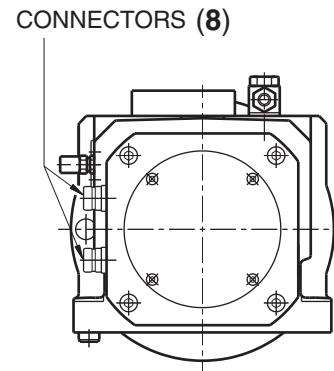
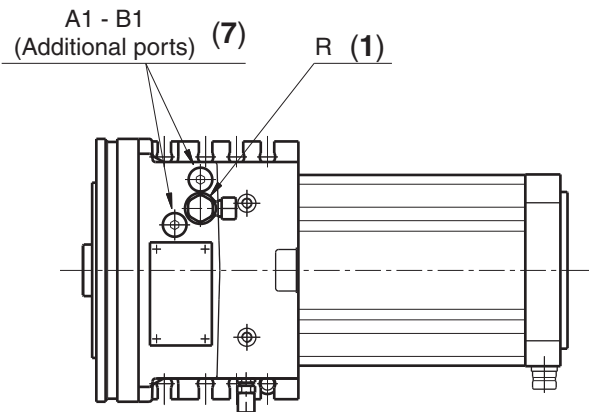
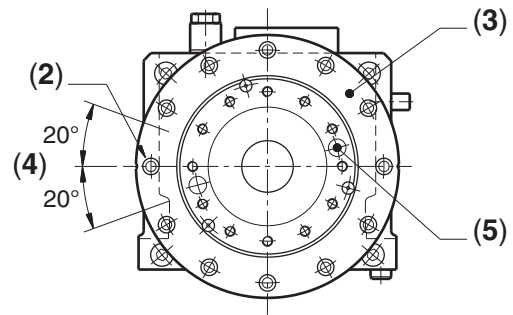
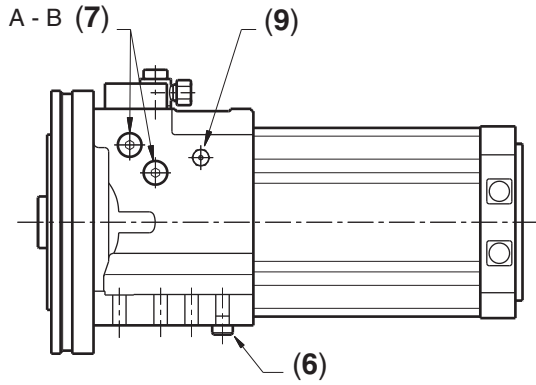

BACK VIEW

- 1) Inlet coolant position. The left version is supplied with a 90° fitting.
- 2) Coolant outlet position.
- 3) Adjustable coolant ring.
- 4) Coolant outlet displacement range.
- 5) Positions for boring the disc reference pins.
- 6) Reference pin.

- 7) Hydraulic connections.
- 8) Electrical connectors.
- 9) Safety valve (drain).

Note: Overall dimensions and fixing interchangeable with SM★ turrets.

DM-* / series 10 HYDRAULIC DIAGRAM

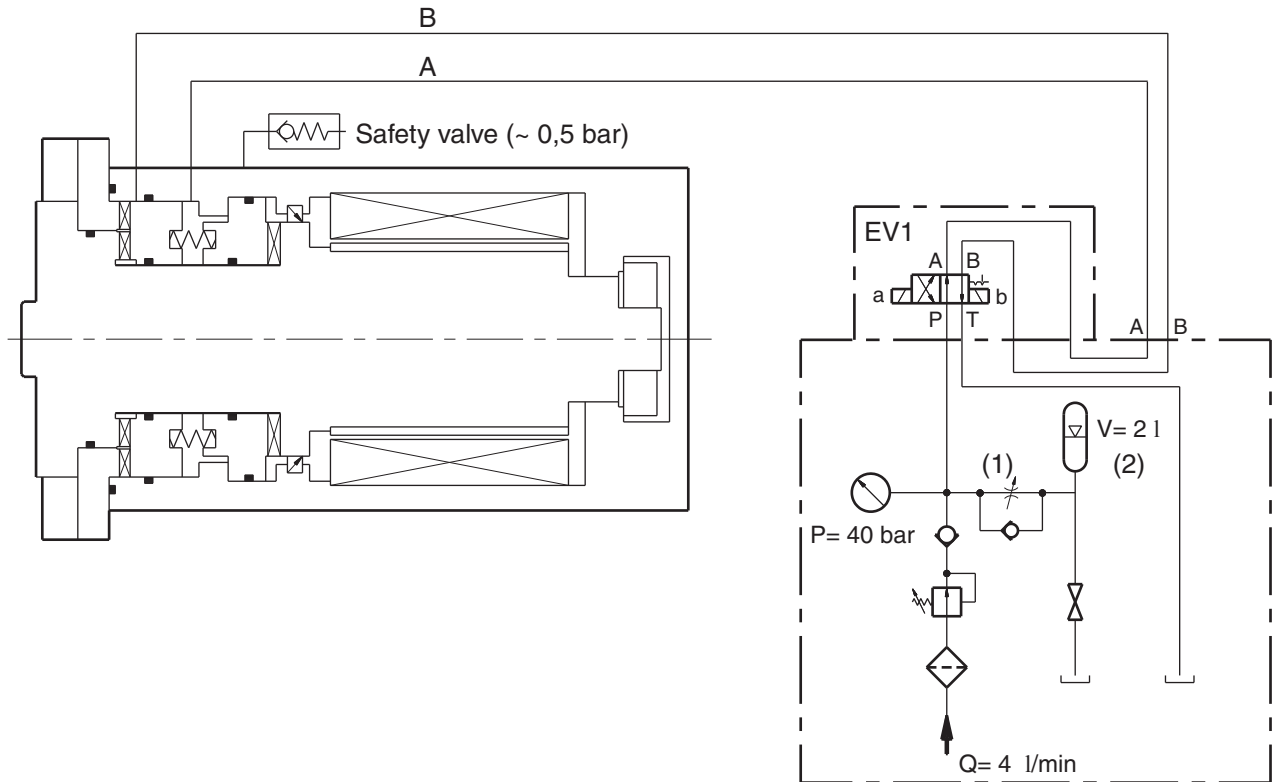

HYDRAULIC POWER PACK (Example)

- (1) **IMPORTANT:** A flow adjustment valve must be foreseen in order to avoid a violent or noisy clamping.
- (2) The accumulator's volume is according to the real pump flow rate.

Supply:

- Working pressure 40 ±5 bar
- Filtering 20 µm
- Oil viscosity 32 ÷ 46 mm²/s
- Recommended oil temperature 35 ÷ 55 °C

Size	DM	12	16	20	25
Required oil volume					
[cm ³]	Clamping	18,5	28	61,5	65,5
	Unclamping	18,5	28	61,5	65,5
Needed instant flow [l/m]		8	12	20,5	19
for Tb		0,14 s	0,14 s	0,18 s	0,22 s

Functions	EV1	
	sol. a	sol. b
Clamping turret	-	+
Unclamping turret	+	-

Connections on the turret					
A – (A1)	GAS	1/4"	1/4"	3/8"	3/8"
B – (B1)	GAS	1/4"	1/4"	3/8"	3/8"

DN recommended nominal diameter for hydraulic line					
Lenght	≤ 6 m	6	8	10	10
	> 6 m	8	10	12	12

DM-* / series 10 WIRING DIAGRAM

The **DM*** turrets are supplied with a proper **TMC-* Direct motor driver** for remote installation inside the machine electrical cabinet.

The turret-side electrical connections are carried-out by connectors.

IMPORTANT : In the machine electrical cabinet proper electrical protection devices must be foreseen. (i.e. fuses).

For all details and specs about electrical connections and interfacing to CNC, please refer to relevant Electrical Manual **E.M. TMC-***.

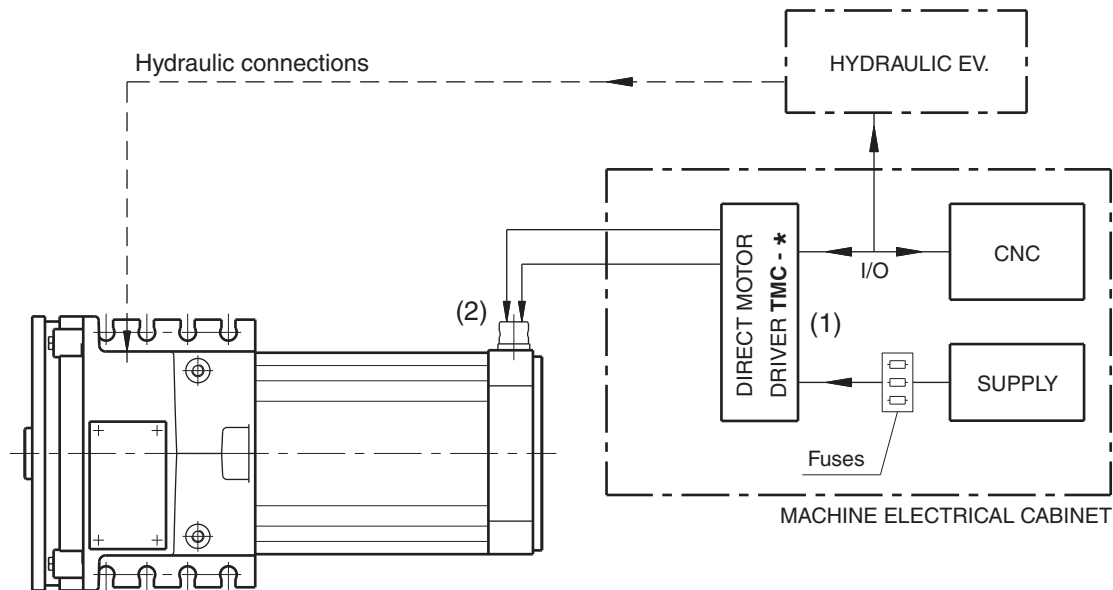

(1) Included in our supply : **TMC-* Direct motor driver.**

Excluded from our supply : Fuses and whatever not clearly mentioned.

(2) Connectors (Turret side).

SUPPLY	DM-*	
• Power input 3~	400VAC +15% -10% 16A max	230VAC +15% -10% 23A max
• Auxiliary supply DC	24VDC ±10% 50W	
• Frequency range	50/60Hz ±2Hz	
SPECS FOR POWER TRANSFORMER:		
• Secondary rate voltage	400 VAC ±10% - 3~	230 VAC ±10% - 3~
• RATED POWER	1,5 KVA	
• Max voltage drop at 16A RMS	5%	
• Connections	STAR-STAR / DELTA STAR	
• Secondary voltage deviation	±2%	

INPUTS	DM-*	
• Voltage range	24 Vd.c. ±10%	
• Current	5mA (24 Vd.c.)	
OUTPUTS		
• Transistor MOS N.O. (source)		
• Max voltage	24 Vd.c. ± 10%	
• Max current	2,0A	(Power)
	30mA	(Signal)
• Operating temperature (turret)	0 ÷ 55°C	
• Humidity	30 ÷ 95%	
• Vibration:	1 G max	

Overall dimensions

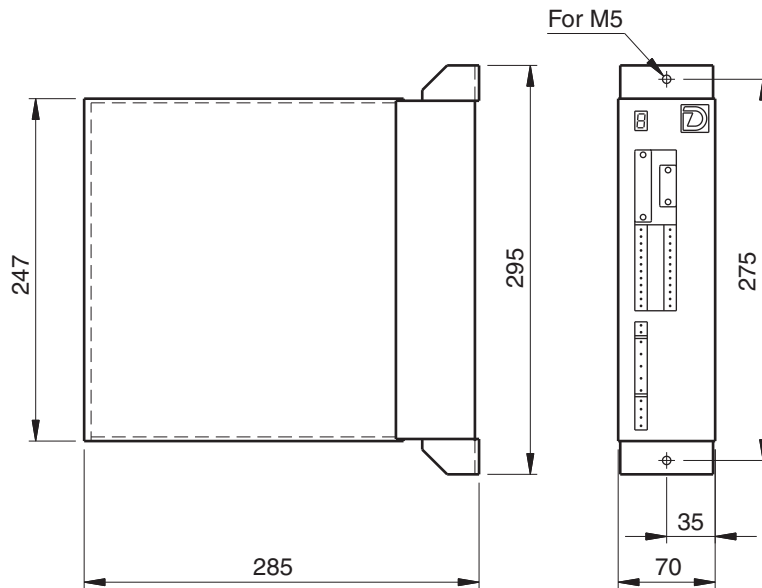

NOTE: Foresee at least 20 mm of free space on both sides and at least 100 mm above and below to allow connections and cooling airflow.

How to connect

POWER CONNECTORS

		CABLE SIDE
CN10	AC supply 3 ~	Phoenix GMSTB 2,5/4-ST-7,5
CN11	Motor power	Phoenix GMSTB 2,5/5-ST-7,5

SIGNAL CONNECTORS

		CABLE SIDE
CN1	Digital OUTPUTS	Phoenix MSTB 2,5/12-ST
CN2	Digital INPUTS	Phoenix MSTB 2,5/12-ST
CN8	24VDC	2P female 5mm-CPF 5/2
CN7	Signal to/from turret	SUB-D 25 male DIN 41652 (1)
CN9	RS232 serial connection	SUB-D 9 female DIN 41652 (1)

(1) Not supplied

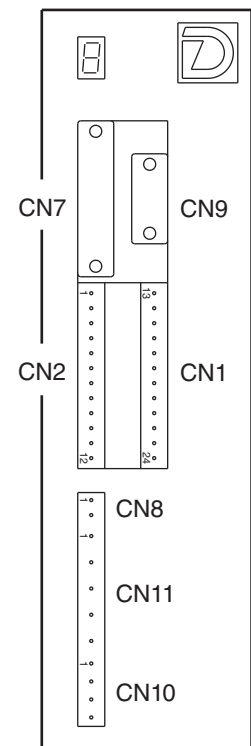

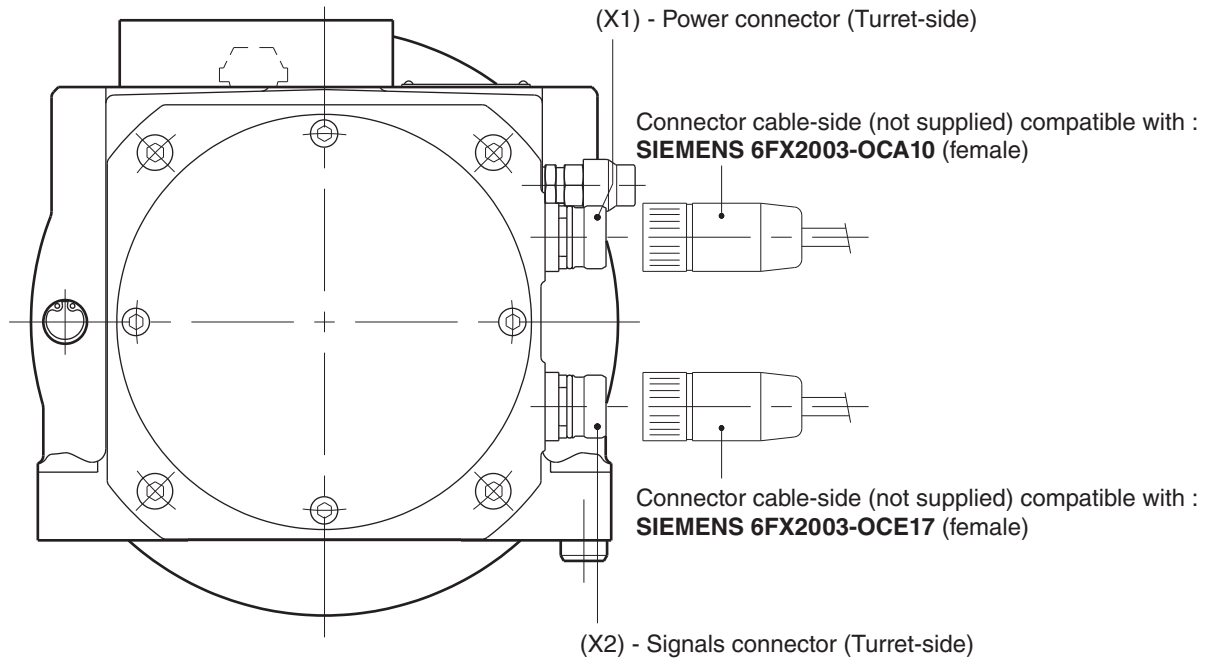

Connectors (Turret-side)

(X1) **POWER: AFEA 06 CMRSN 000 male**
Panel mount socket for male contacts.

(X2) **SIGNAL: SFOA 17A MREN 000 male**
Panel mount socket for male contacts (n° 17).

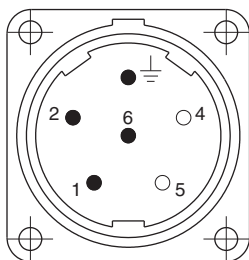

— View from mating side
— Contacts 4 and 5 not used.

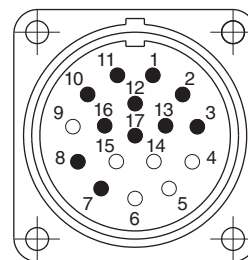

— View from mating side.
— Contacts 4-5-6-9-14-15 not used.

"DM★" turrets have been designed for modular fitting of different driven tool systems

DM★-DT

- With **ODT-N** driven tool device.
- Tool coupling according to DIN 1809.
- Tool disc with **axial** seats.
- Front machining.

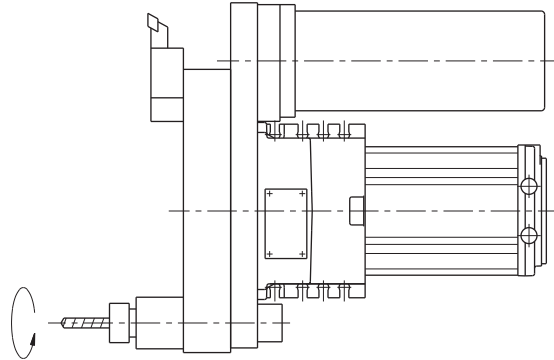

DM★-MDT

- With **MDT** driven tool device.
- Tool coupling according to DIN 5480 / 5482
- Tool disc with **axial** seats.
- Front machining.

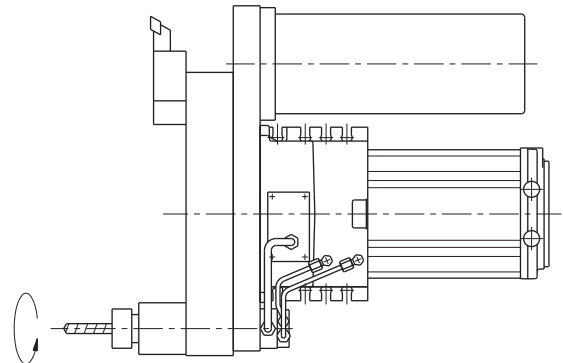

For further information please contact our Technical Dept.

DM-★ / series 10 IDENTIFICATION CODE

DM - ★ - ★ - ★-★ - ★ / 1★ - ★ - ★

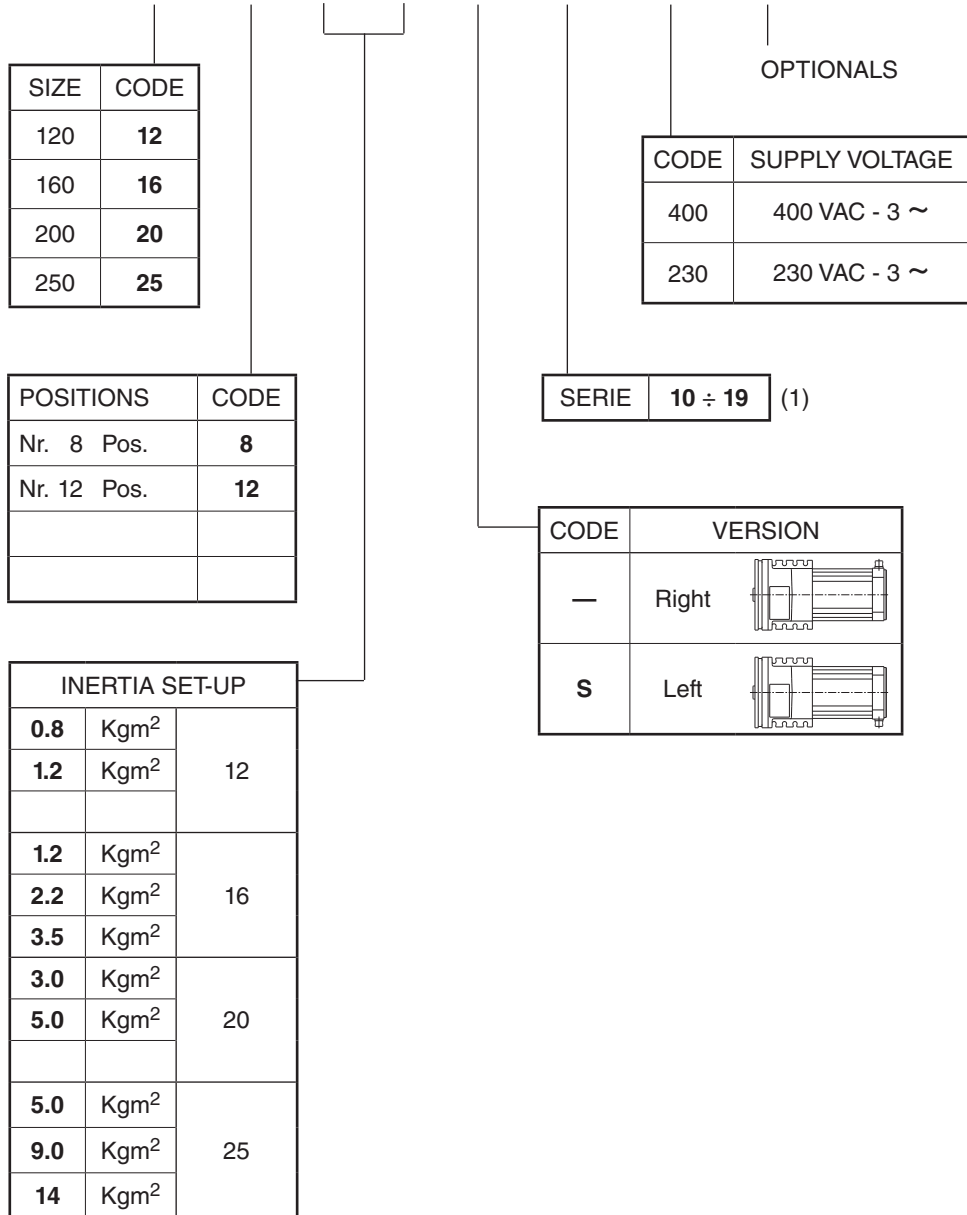

(1) From 10 to 19 the performance and the overall dimensions do not change.

DIPLOMATIC AUTOMATION S.r.l.
20025 LEGNANO (MI) - ITALY
P.LE BOZZI, 1
PHONE 0331/472111
FAX 0331/455161



DIPLOMATIC
AUTOMATION

e-mail: info@diplomatic.it

come visit Diplomatic homepage:
www.diplomaticautomation.com